

ONKYO® SERVICE MANUAL

DUAL SUPER SERVO STEREO POWER AMPLIFIER MODEL M-5060

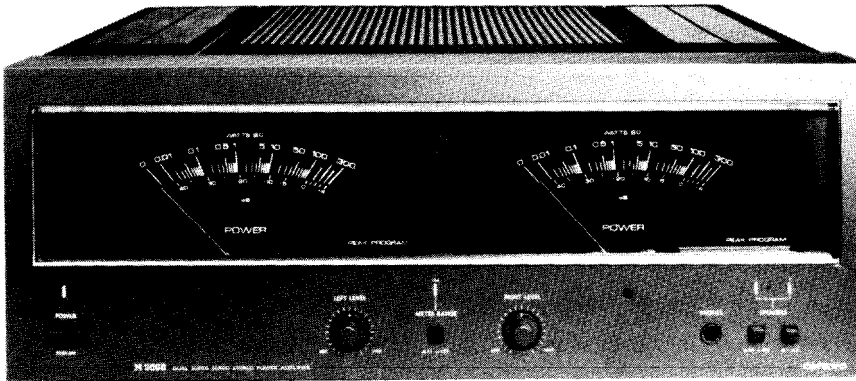

TABLE OF CONTENTS

Item	Page
Specifications	2
Features	2
Block diagram	3
Circuit description	3
Adjustment	4
Connection diagram	5
Component location	6
Precautions	7
Exploded view	8
Schematic diagram	9
Printed circuit board view	11
Packing procedures	16

ONKYO®
AUDIO COMPONENTS

SPECIFICATIONS

D Model

Power Output:	120 watts per channel, min. RMS, at 8 ohms both channels driven, from 20 Hz to 20 kHz, with no more than 0.005% total harmonic distortion.
Total Harmonic Distortion:	0.005% at Rated power 0.005% at 1 watt output
Intermodulation Distortion:	0.005% at Rated power
Frequency Response:	+0, -1.5 dB at 1 Hz ~ 100 kHz
Input Sensitivity:	1.5 V
Input Impedance:	47 k Ω
Damping Factor:	140 (8 Ω , 1 kHz)
Signal to Noise Ratio:	94 dB (IHF A-202)
Power Supply Rating:	AC120 V 60 Hz
Outputs:	SPEAKERS 1 & 2, AC OUTLET, PHONES
Inputs:	INPUT P
Semiconductors:	2 FETs, 47 Transistors, 40 Diodes, 6 ICs
Dimensions:	450 (W) x 174 (H) x 400 (D) mm (17-3/4" x 6-7/8" x 15-3/4")
Weight:	17.8 kg (39.2 lbs.)

Specifications and features are subject to change without notice.

G Model

Power Output:	120 watts per channel, min RMS, at 8 ohms both channels driven, from 20 Hz to 20 kHz, with no more than 0.005% total harmonic distortion.
Total Harmonic Distortion:	0.005% at Rated power 0.005% at 1 watt output
Intermodulation Distortion:	0.005% at Rated power
Frequency Response:	+0, -1.5 dB at 1 Hz ~ 100 kHz
Input Sensitivity:	1.5 V
Input Impedance:	47 k Ω
Damping Factor:	140 (8 Ω , 1 kHz)
Signal to Noise Ratio:	94 dB (IHF A-202)
Power Supply Rating:	AC220 V 50 Hz
Outputs:	SPEAKERS 1 & 2, PHONES
Inputs:	INPUT P.
Semiconductors:	2 FETs, 47 Transistors, 40 Diodes, 6 ICs
Dimensions:	450 (W) x 174 (H) x 400 (D) mm (17-3/4" x 6-7/8" x 15-3/4")
Weight:	17.8 kg (39.2 lbs.)

Specifications and features are subject to change without notice.

FEATURES

1. Dual Super-Servo System

Adapting the present super-servo to dual system has made control of the total positive and negative signal path possible, thereby cutting out a number of internally generated distortion sources. Power supply and ground source distortion has been reduced and improvement has been particularly dramatic in the power amp where distortion has a pronounced effect on tonal quality.

2. Linear Switching System

Linear switching is used in the output stage of the power amp. Operationally this is the most simple method and produces the best results. Also, using a high FT (cut-off frequency) transistor has completely eliminated switching distortion improving sound purity.

3. High Quality and High Power

Based on monaural construction, 120 watts per channel with 0.003% distortion at rated output. Starting with the dual super-servo, the most advanced technology available writes new standards for music reproduction.

4. Quick Responding, Large Peak Meters

Large, quick response dual level meters with 65mm needles have been selected for the M-5060. These meters work in conjunction with the transient killer circuit and protection circuit, providing a means to monitor operation. Power meter illumination is also featured.

5. Dual Super-Servo System Power Section

This unit forms the power section for the P-3060 Dual Super-Servo amp system. This combination maximizes all the advantages of the total system. Naturally, it may be used with other preamps and still retain all the merits inherent in its dual super-servo design.

6. Dual Power Supply – Dual Monaural Amp Construction

Two large power supplies constructed using parts selected under the most critical criteria help maintain musical purity.

BLOCK DIAGRAM

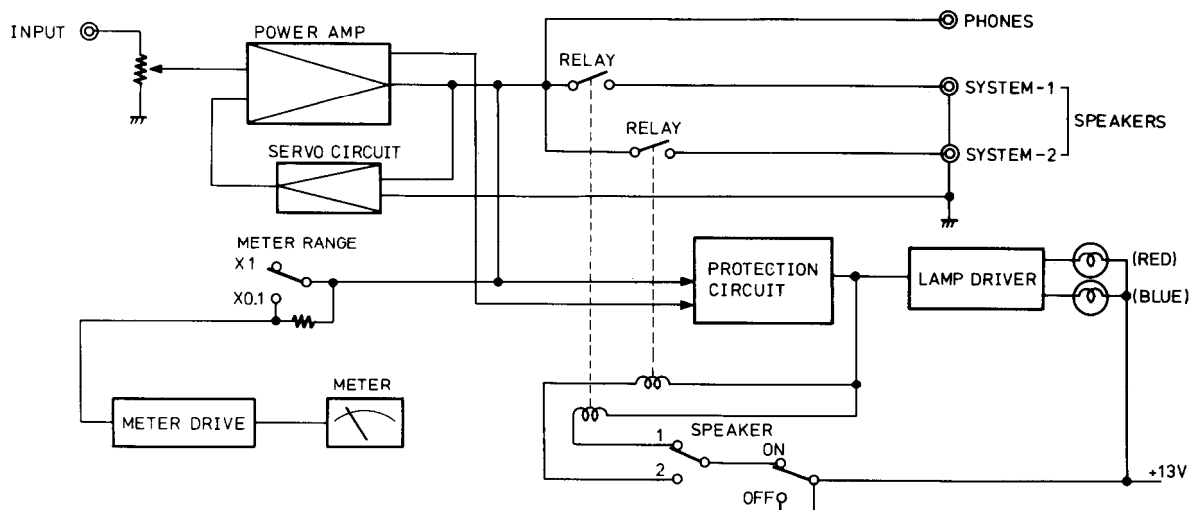

CIRCUIT DESCRIPTION

Dual Super-Servo

When a musical note in the form of a signal is reproduced in an amplifier, if only the input signal were faithfully reproduced everything would be fine. But in reality, a number of other signal components not musical in origin (mainly ultralow frequency noise from mechanical sources) are input along with the musical signal. There are also various undesirable distortions generated internally within the amp itself. This is particularly true of a DC amp simply because of its wide bandwidth. Its ability to amplify signals at low frequency means that these undesired ones are also amplified, resulting in a modified harmonic.

With the super-servo system, the DC amp used to amplify musical signals is controlled by a separate servo amp, eliminating undesirable ultralow frequency components and suppressing thermal noise generated by the preamp. It also allows coupling without the use of capacitors between the input and output of the amp. However, with the dual super-servo, a servo has been added to the negative side (ground-side) of the amp, maintaining ground reference at 0 and suppressing any undesirable signals (meaning distortion) caused by ground impedance. Ground is considered the reference point on amps and should be maintained at 0, but due to the various contact resistances and impedances, it is in fact almost impossible to do. Especially on large current carrying power amps. In past attempts to solve this problem, larger power supplies have been used and busbars employed to lower ground impedance, but as a practical matter heavy gauge wiring and busbars cannot be used throughout the signal path and for ground wires, and even if they could, it would still be impossible to keep ground impedance at 0. This problem is solved in the dual super-servo system.

The signal ground point is perfectly locked with a separate servo; distortion caused by fluctuations in the ground and power supply or due to connector impedance between the pre and main amp has been completely eliminated with a resulting improvement in tonal quality.

Power amp M-5060 is in itself a dual super-servo amp, however, connected to preamp P-3060 using a super-servo cord will result in even better sound improvement.

ADJUSTMENTS

1. Preparations

- (1) When making adjustments, lower the pedestals of the unit and set it on a level bench. Make sure a space of at least 15 mm exists between the bench and the bottom of the unit for ventilation.
- (2) Place the unit at lowest level, no load, and no signal.
- (3) During adjustment, any drafts in the room will cause unstable readings.

2. Adjusting the meter to ZERO

- (1) With the power supply OFF, adjust the screw on the lower part of the meter until the needle is on 0.
- (2) Do not make this adjustment immediately after turning OFF the power supply. Wait until the meter circuit has discharged.

3. Adjusting idling current

- (1) Remove the cover. Turn ON the power supply to obtain voltage between VCT and IID of board NAMA-752. After waiting 5 minutes, adjust VR R4039 (R4040) until a reading of 12 mV is obtained. (After 20 minutes of stabilization, the reading should be 16 mV.)
- (2) After the above adjustment is completed, make certain the voltage reading between VCT and the emitters of Q4025 (Q4026), Q4029 (Q4030), and Q4031 (Q4032) is approximately the same. When making this test, use a 100 Ω resistance between the testing device and emitter as shown in the drawing at right.

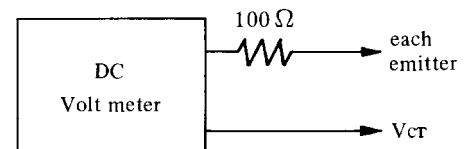

4. Adjusting meter offset

After the power supply switch is ON, wait 5 minutes and without signal input, adjust OFFSET VR R1040 (R1041) on board NAME-758 to the point the meter reads 0.

5. Meter level adjustment

Apply a 1 kHz test signal to the INPUT terminal of the left channel and set the M-5060 meter ranging switch to X 0.1. Adjust input to the point the voltage reading (no load) at the speaker output is 9.8 V (19.82 dBV), and adjust LEVEL VR R1014 (R1015) on board NAME-758 until the meter reads 0. Adjust the right channel the same way. (Do not apply signals to the right and left channel simultaneously.)

NOTE: The numbered transistors and variable resistors in paranthesis () apply to the right channel.

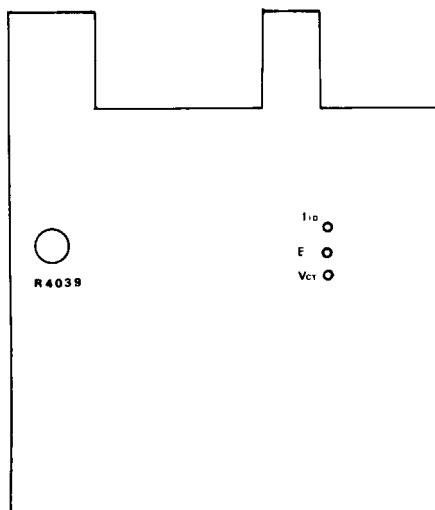

Power amp. p.c.b.
Adjustment point

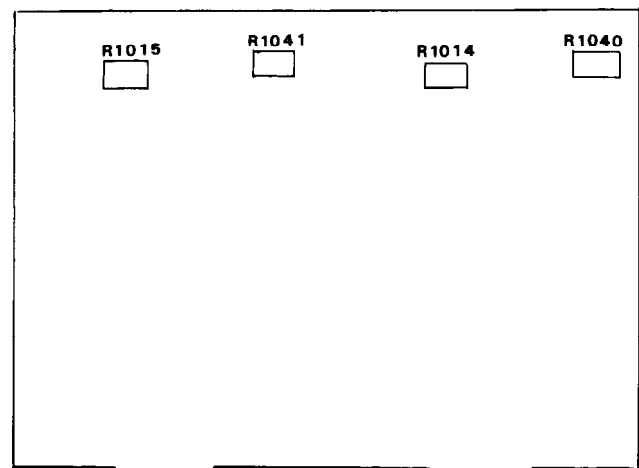

Meter circuit p.c.b.

CONNECTION DIAGRAM

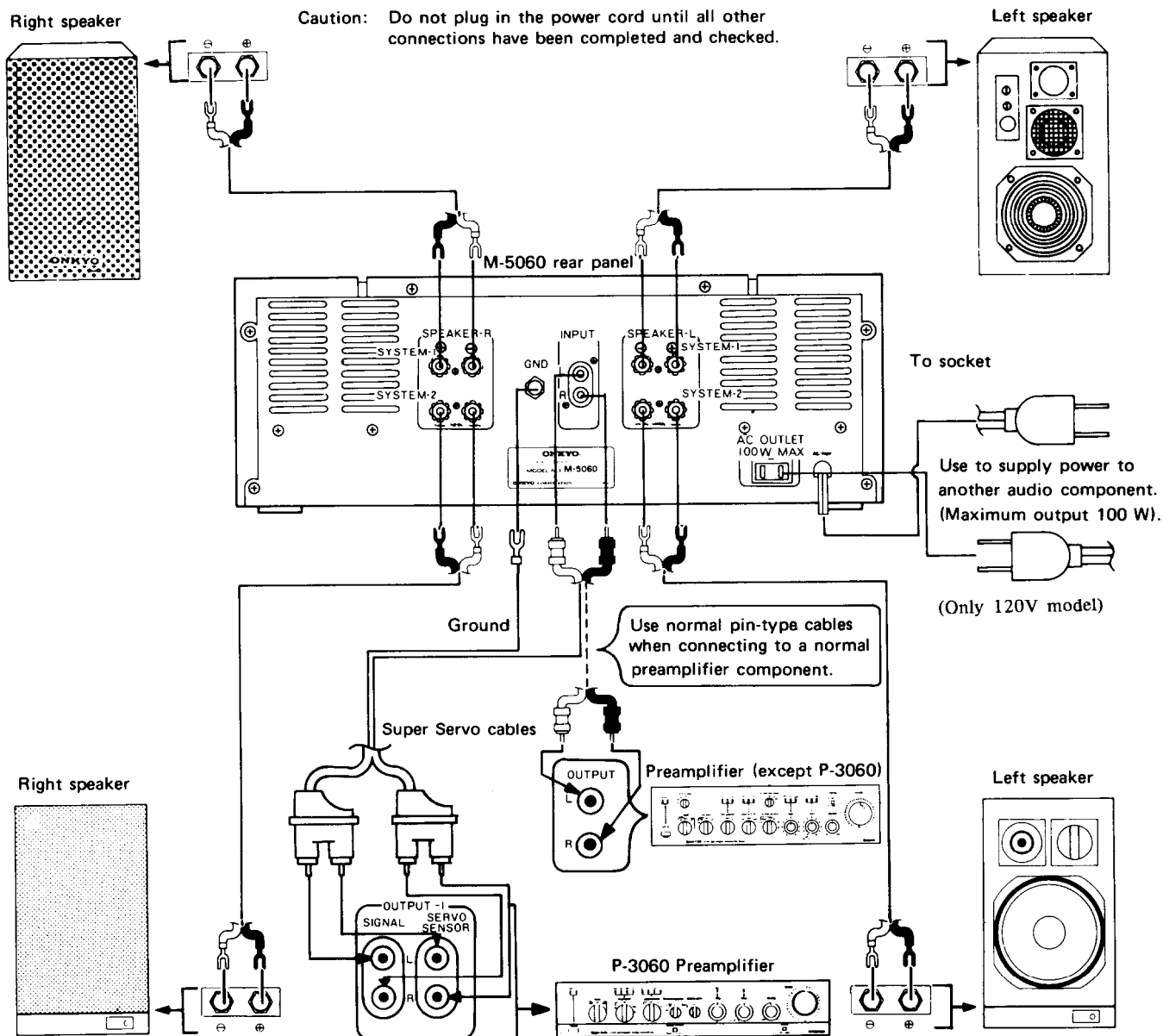

- It is recommended that the Onkyo P-3060 preamplifier be used with the M-5060 because the P-3060 features the same Dual Super Servo system. In this case, connect the M-5060 and P-3060 to each other with the special Super Servo cables supplied (these cables are supplied only with the P-3060). However, if a different preamplifier is connected to the M-5060, use normal pin-type connecting cables.
- Since the M-5060 is a high grade high power amplifier component, use only high grade speaker systems capable of doing justice to the excellent quality of sound reproduction achieved by the M-5060.
- Note that although the allowable speaker impedance range is $4\ \Omega$ to $16\ \Omega$, the speaker systems selected for use with the M-5060 should have a high power handling capacity. If speaker systems of low maximum input power rating are used and the volume level is increased to very high levels, the speakers will probably be damaged. Check the maximum input power rating before connecting to the M-5060.
- Use sturdy coaxial speaker cables for the speaker connections. The use of thin leads is not recommended because the resultant higher speaker lead impedance will affect the quality of sound reproduction.
- In order to protect speakers from possible damage, always turn the M-5060 power switch off before connecting (or disconnecting) the speaker systems.
- Be particularly careful not to short circuit the speaker cables at any time.
- Keep the power cord away from the pin-type cables and speaker cables since close proximity can result in induction hum.

COMPONENT LOCATION

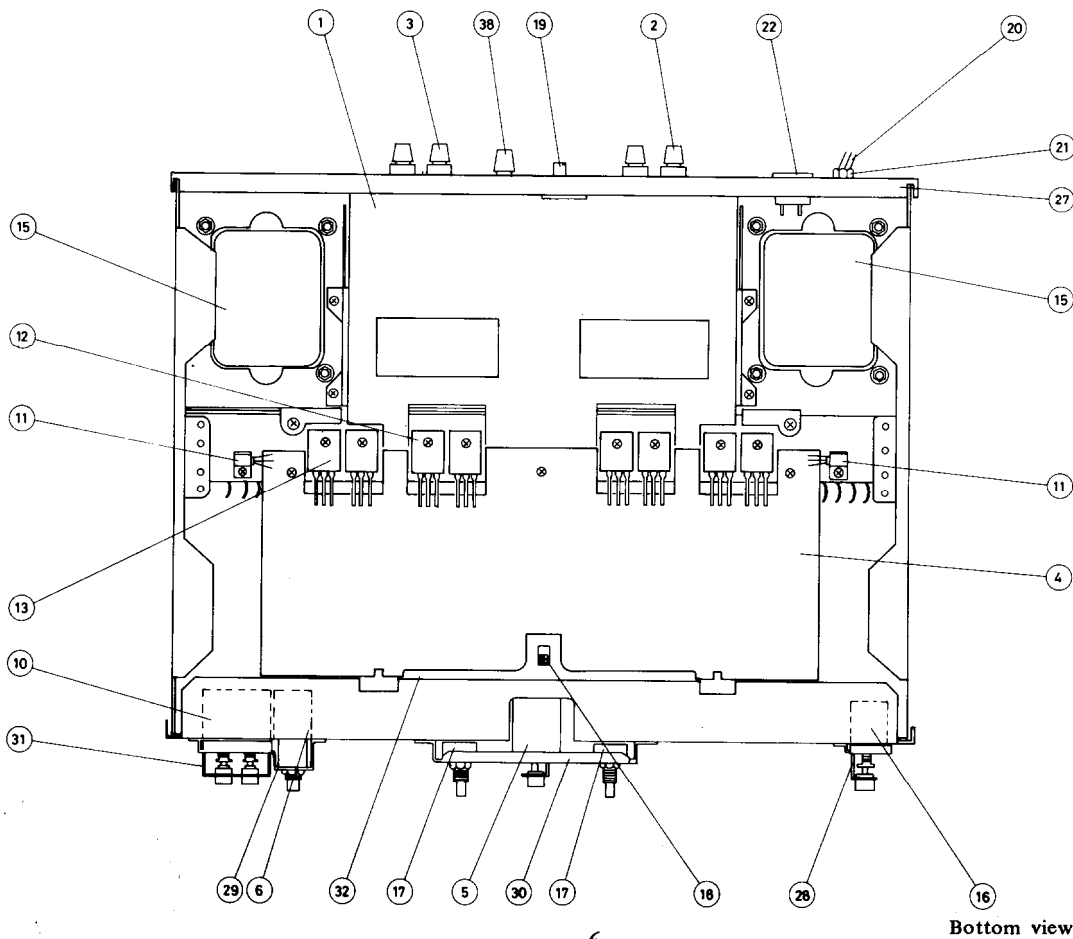
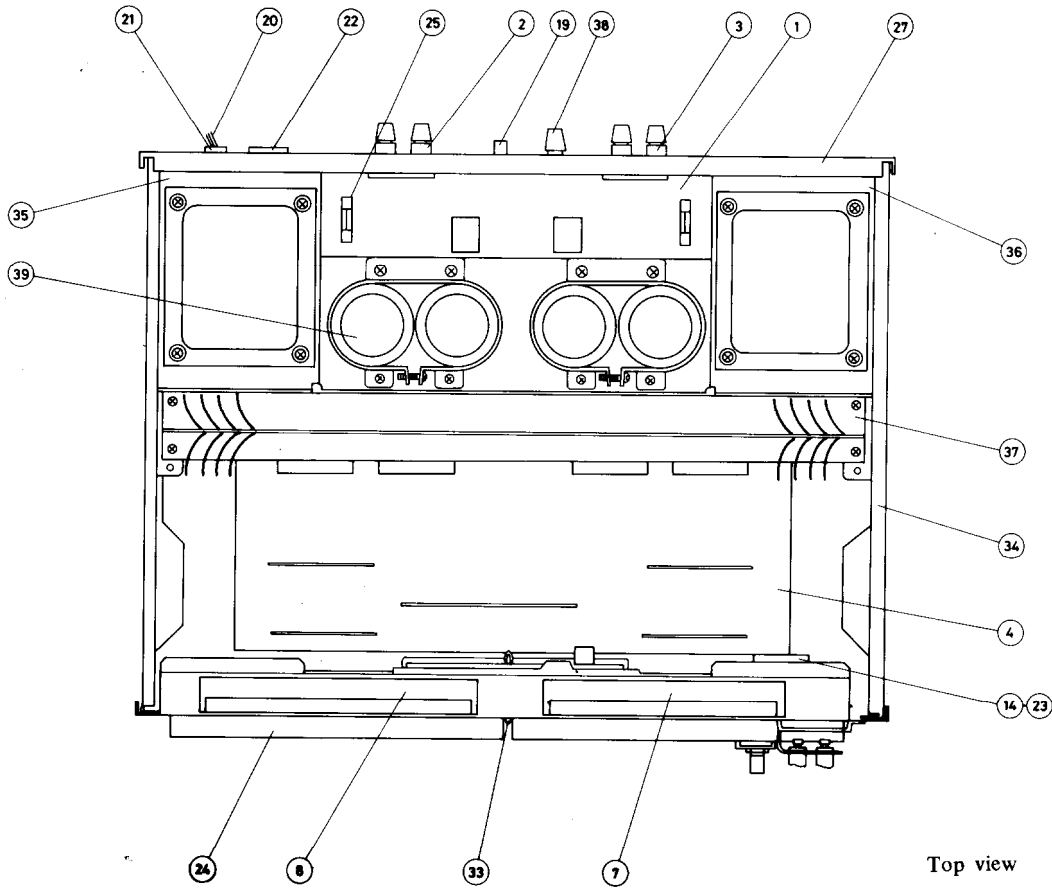

COMPONENT LOCATION — PARTS LIST

D Model				G Model			
REF. NO.	CIRCUIT NO.	PARTS NO.	DESCRIPTION	REF. NO.	CIRCUIT NO.	PARTS NO.	DESCRIPTION
1	U001	12609549B	NAPS-749b, Protector/rectifier circuit pc board ass'y	1	U001	12612549C	NAPS-749C, Protector/rectifier circuit pc board ass'y
2	U002	12732550	NAOP-750, Left side speaker terminals pc board ass'y	2	U002	12732550	NAOP-750, Left side speaker terminals pc board ass'y
3	U003	12732551	NAOP-751, Right side speaker terminals pc board ass'y	3	U003	12732551	NAOP-751, Right side speaker terminals pc board ass'y
4	U004	12732552	NAMA-752, Power amplifier pc board ass'y	4	U004	12732552	NAMA-752, Power amplifier pc board ass'y
5	U006	12609554A	NASW-754a, Meter range selector pc board ass'y	5	U006	12609554A	NASW-754a, Meter range selector pc board ass'y
6	U005	12732553	NAHP-753, Headphone terminal pc board ass'y	6	U005	12732553	NAHP-753, Headphone terminal pc board ass'y
7	U008	12732556	NAPL-756, Meter illumination lamp pc board ass'y	7	U008	12732556	NAPL-756, Meter illumination lamp pc board ass'y
8	U009	12732557	NAPL-757, Meter illumination lamp pc board ass'y	8	U009	12732557	NAPL-757, Meter illumination lamp pc board ass'y
9	U010	12732558	NAME-758, Meter drive circuit pc board ass'y	9	U010	12732558	NAME-758, Meter drive circuit pc board ass'y
10	U007	12609555B	NASW-755b, Speaker selector pc board ass'y	10	U007	12609555B	NASW-755b, Speaker selector pc board ass'y
11	Q4013,Q4014	2211255	2SC1815(GR), Thermal detector transistor	11	Q4013,Q4014	2211255	2SC1815(GR), Thermal detector transistor
12	Q4025,Q4026 Q4027,Q4028	2201164 or 2201163	2SC2581(Y) or 2SC2581(O), Power amplifier transistor	12	Q4025,Q4026 Q4027,Q4028	2201164 or 2201163	2SC2581(Y) or 2SC2881(O), Power amplifier transistor
13	Q4029,Q4030 Q4031,Q4032	2201154 or 2201153	2SA1106(Y) or 2SA1106(O), Power amplifier transistor	13	Q4029,Q4030 Q4031,Q4032	2201154 or 2201153	2SA1106(Y) or 2SA1106(O), Power amplifier transistor
14	D001	223848 or 223804	GP08B or SR1K-2, Silicon diode	14	D001	223848 or 223804	GP08B or SR1K-2, Silicon diode
15	T001,T002	230391	NPT-690D, Power transformer	15	T001,T002	230392	NPT-690G, Power transformer
16	C001	3500054	125V, 0.01 μ F, CS capacitor	16	C001,C002	3500058	PME265MB510, IS capacitor
	S001	25035061A	NPS-121-L26P, Power switch		S001	25035176	NPS-111-L140, Power switch
17	R001,R002	5146016	N16R100KB25M, Output level variable resistor	17	R001,R002	5146016	N16R100KB25M, Output level variable resistor
18	S002	25065126	NSS-2259, Slide switch	18	S002	25065126	NSS-2259, Slide switch
19	P001	25045048	NPJ-2PRBL23, Input terminal	19	P001	25045048	NPJ-2PRBL23, Input terminal
20	P003	253100	AS-UC-4, Power supply cord	20	P003	253092	AS-CEE-2, Power supply cord
21		270280	SR-4K-4, Strainrelief	21		270280	SR-4K-4, Strainrelief
22	P004	25050032	S-I 6444-02, AC outlet	23	RL001	25065104	NRL-4P3A-DC12-03, Relay
23	RL001	25065104	NRL-4P3A-DC12-03, Relay	24	M001,M002	243113	NIND-2000S113, Output meter
24	M001,M002	243113	NIND-2000S113, Output meter	26	A001	27110097	Front bracket
25	F101,F102	252050	5A, ST-6, Fuse	27		27120239	Back panel
26	A001	27110097	Front bracket	28		27140313	Bracket, power
27		27120238A	Back panel	29		27140314	Bracket, headphone
28		27140313	Bracket, power	30		27140315	Bracket, volume
29		27140314	Bracket, headphone	31		27140316	Bracket, lamp
30		27140315	Bracket, volume	32		27130219	Bracket, pc board
31		27140316	Bracket, lamp	33		27190062	Holder
32		27130219	Bracket, pc board	34		27115053B	Side bracket
33		27190062	Holder	35		27130172	Bracket, power transformer
34		27115053B	Side bracket	36		27130173	Bracket, power transformer
35		27130172	Bracket, power transformer	37		27160060	Radiator
36		27130173	Bracket, power transformer	38	P002	TP160B	Ground terminal
37		27160060	Radiator	39	C101-C104	3504126	18, 000 μ Fx2, 69V, Elect. capacitor
38	P002	TP160B	Ground terminal		F001-F002	252075	2.5A-SE-EAK, Fuse
39	C101-C104	3504126	18, 000 μ Fx2, 69V, Elect. capacitor		F003-F006	252078	5A-SE-EAK, Fuse
					F007-F008	252070	1A-SE-EAK, Fuse
					F001-F008	25065096	Fuseholder

PRECAUTIONS

- For continued protection against fire hazard, replace only with same type and same rating fuse.

AC fuse	CIRCUIT NO.	PARTS NO.	DESCRIPTION	
	F101, F102	252050	5A (ST-6)	120V model
	F101, F102	252075	2.5A SE-EAK	
	F003-F006	252078	5A SE-EAK	220V model
	F007, F008	252070	1A SE-EAK	

- Replacement for power, complementary and driver transistors, if necessary, must be made from the same beta (HFE) group as the original type.

- Super Servo Switch

A super servo switch is located in the base of this unit to turn the dual super servo circuitry on and off. Slide the switch with a screwdriver or similar instrument. To compare music played back with dual and normal super servo, use a selection with plenty of depth such as an orchestral or choral performance. First listen at the dual setting, then replay the same section at the super servo setting. At the factory, this switch is set to the dual super servo position; it should be left in this position during normal playback to take advantage of the dual super servo circuitry.

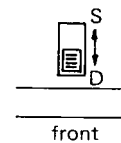

EXPLODED VIEW

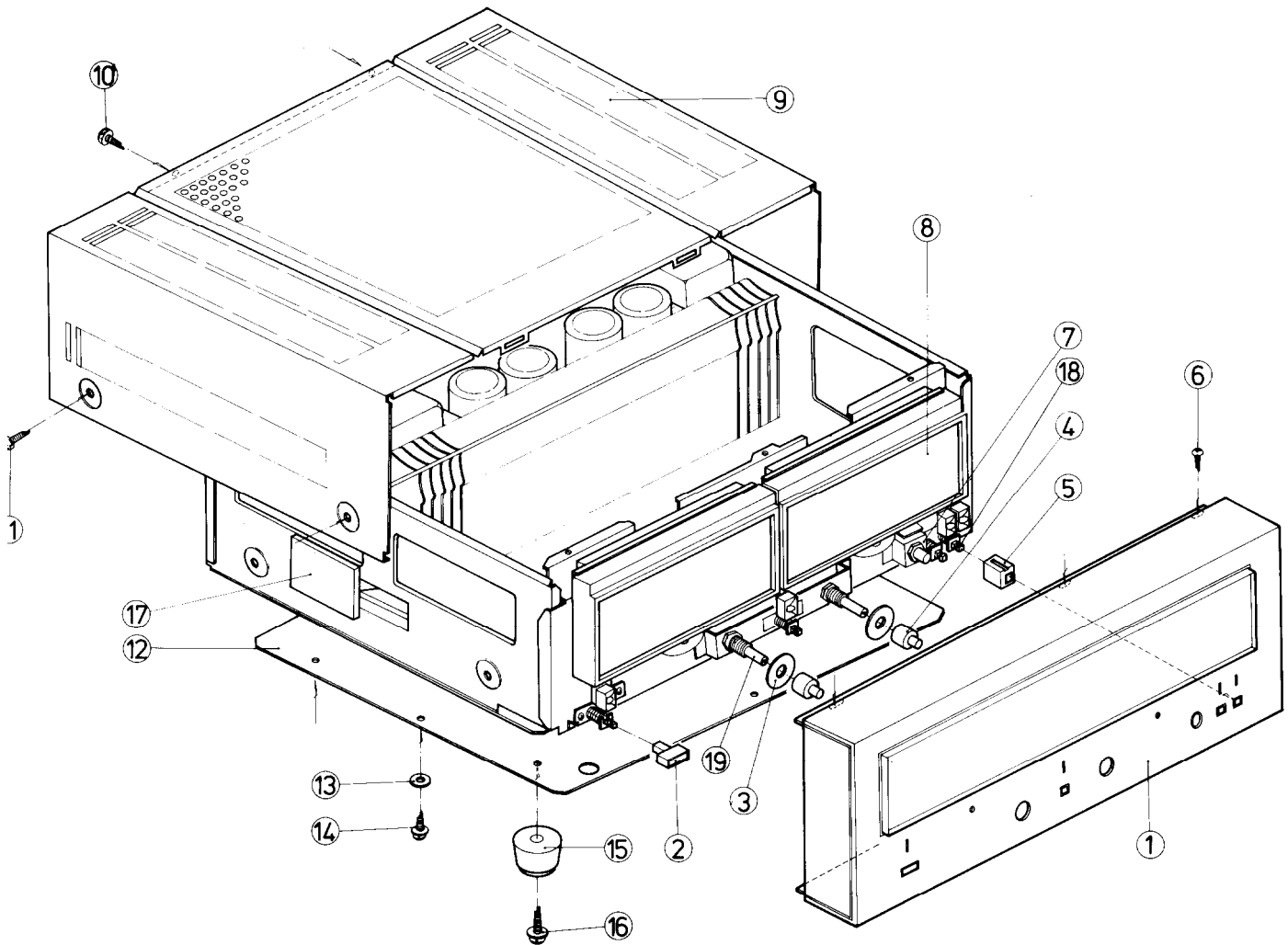

EXPLODED VIEW – PARTS LIST

REF. NO.	PARTS NO.	DESCRIPTION	REF. NO.	PARTS NO.	DESCRIPTION
1	12609121	Front panel ass'y	8	243113	NIND-2000S113, VU meter
	27210155	Panel (S)	9	28184067	Top cover
	28191047	Glass plate		28140020	Cushion
	28125074	End cap	10	838440109	4TTB+10C(BC), Tapping screw
	28198523A	Facet	11	838440109	4TTB+10C(BC), Tapping screw
	27267056	Guide, power knob	12	27170082	Bottom board
	28140218	145×6×7 t, Cushion (Glass plate)	13	870048	Nylon washer
	834430062	3STS+6BQ(BC), Tapping screw	14	831430082	3STW+8BQ, Tapping screw
2	28320279	Knob, power switch	15	280889A	Leg
3	28140127	Cushion	16	831130162	3STW+16BQ, Tapping screw
4	28320375A	Knob, volume	17	27270041	Spacer
5	12792125	Push knob ass'y	18	12609555B	NASW-755b, Switch pc board ass'y
6	834430062	3STS+6BQ(BC), Tapping screw	19	5146016	N16R100KB25M, Variable resistor
7	12732553	NAHP-753, Headphone terminal pc board ass'y			

SCHEMATIC DIAGRAM

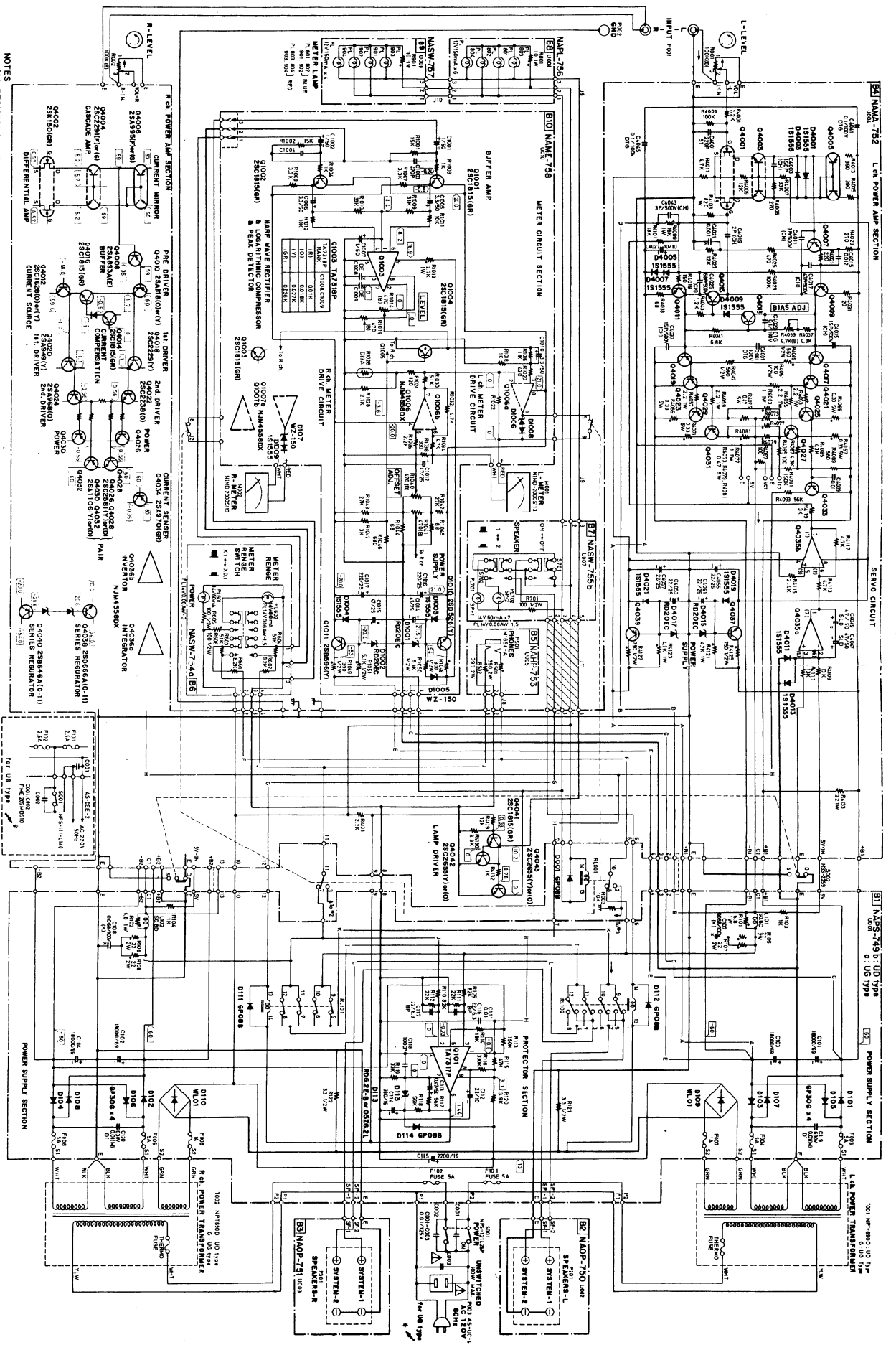

NOTES
 *ALL RESISTORS ARE IN OHMS, $\frac{1}{4}$ WATT UNLESS OTHERWISE NOTED.
 *ALL CAPACITORS ARE IN μ F, 50VW UNLESS OTHERWISE NOTED.
 *ELECTROLYTIC CAPACITORS (E) ARE IN μ F/WV.

*VOLTAGE MEASURED WITH V.T.V.M.(NO INPUT SIGNAL).
 *CURRENT IS SUBJECT TO CHANGE FOR IMPROVEMENT.

NOTE: R003 - F008 UG TYPE ONLY.

POWER AMPLIFIER PC BOARD VIEW FROM BOTTOM SIDE

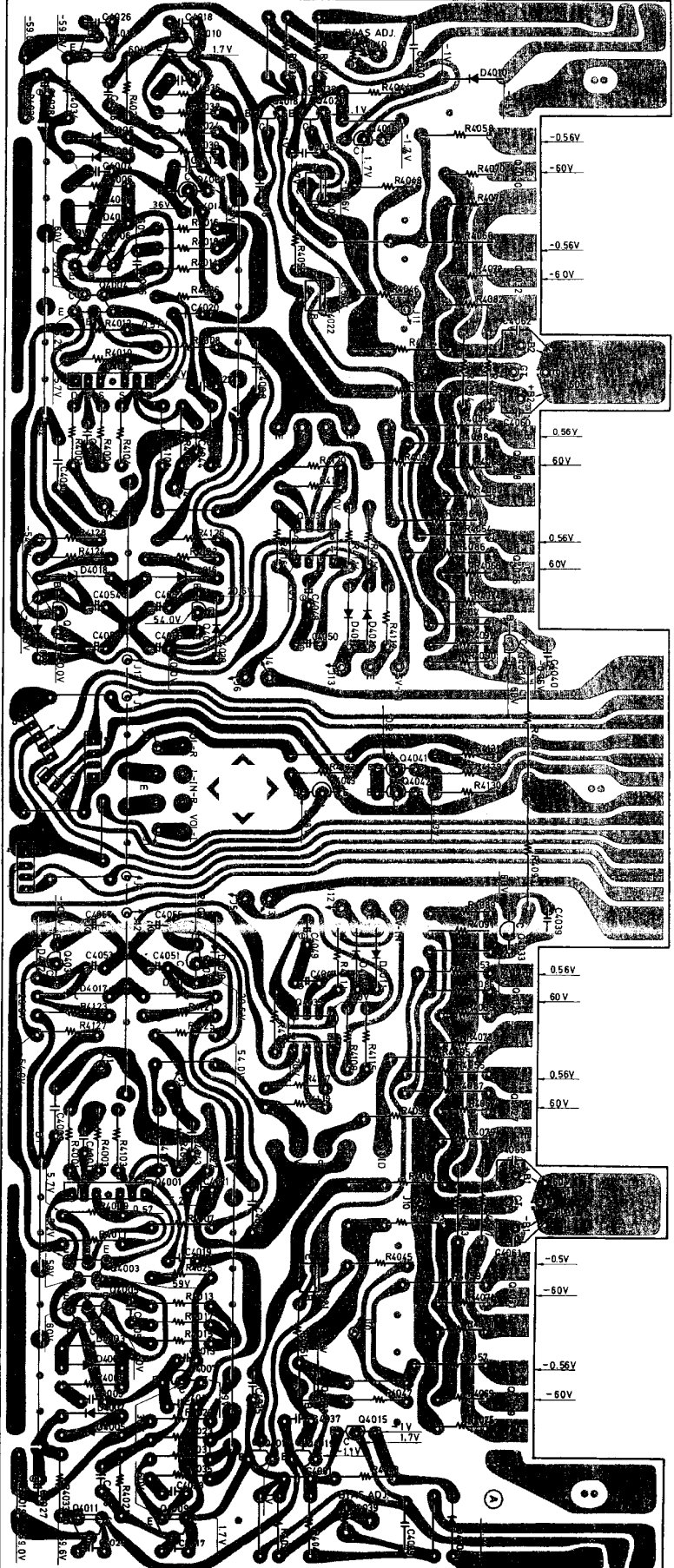

SPEAKER TERMINAL (NAOP-750/751)

- PARTS LIST

CIRCUIT NO.	PARTS NO.	DESCRIPTION
	25060039	NIM-4PDMN10, Speaker terminal
	Q4001, Q4002	Transistors 2SK150(GR), F.E.T.
	Q4003, Q4004	2SK2291(F) or 2SC2291(G)
	Q4005, Q4006	2SK1516 or 2SA993(G)
	Q4007, Q4008	2SA993(G) or 2SA893A(E)
	Q4009, Q4010	2SA818(Y) or 2SA818(O) or 2SC1628(O) or 2SC1628(O)
	Q4011, Q4012	2SC1628(O) or 2SC1628(O)
	Q4013-Q4016	2211255 or 2SC1815(GR)
	Q4017, Q4018	2211634 or 2SC2299(Y)
	Q4019, Q4020	2211354 or 2SA949(Y)
	Q4021, Q4022	2200863 or 2SC2238(O)

HEADPHONE AMPLIFIER PC BOARD (NAHP-753)

- PARTS LIST

CIRCUIT NO.	PARTS NO.	DESCRIPTION
	Q4023, Q4024	2200873 or 2SA968(O)
	Q4025-Q4028	2201164 or 2SC2581(Y) or 2SC2581(O) or 2SA1106(Y) or 2SA1106(O)
	Q4029-Q4032	2201154 or 2SA1106(Y) or 2SA1106(O)
	Q4033, Q4034	2211395 or 2SA970(GR)
	Q4037, Q4038	2211277 or 2SD666A(O)-(11)
	Q4039, Q4040	2211267 or 2SB646A(O)-(11)
	Q4041	2211285 or 2SC1815(GR)
	Q4042, Q4043	2211884 or 2SC2655(CY) or 2SC2655(O)
	Q4035, Q4036	ICs NIM-455BDX
	Q4001-D4014	Diodes 1S1555
	D4015-D4018	RDT20EC
	D4019-D4022	223974 or 1S1535
	C4001, C4002	Capacitors 220PF±10%, 50V, ST
	C4015, C4016	37412125 or 0.012µF±10%, 50V, DE
	C4021, C4022	374121025 or 1.000µF±10%, 50V, DE
	C4027, C4028	352741001 or 10µF, 16V, Elec.
	C4029, C4030	3800003 or 0.1µF, 100V, DTC
	C4031, C4032	3800004 or 0.01µF, 100V, DTC
	C4045, C4046	3800003 or 0.1µF, 100V, DTC
	C4047, C4048	390884707 or 47µF, 50V, SLD
	C4049, C4050	352752201 or 22µF, 25V, Elec.
	C4051-C4058	Resistors N10HR4, 7KBDM, Semi-fixed
	R4039, R4040	5225072 or 560Ω, 1/2W, Metal oxide film
	R4045, R4046	442525614 or 100Ω, 1/2W, Metal oxide film
	R4051, R4052	442521014 or 100Ω, 1/2W, Metal oxide film
	R4053, R4054	442520224 or 2.2Ω, 1/2W, Metal oxide film
	R4055, R4056	4000054 or 0.33Ω, 5W, Metal plate
	R4073, R4074	4000047 or 0.47Ω, 5W, Metal plate
	R4077, R4078	451630104 or 1Ω, 1W, Metal plate
	R4079, R4082	4000047 or 0.47Ω, 5W, Metal plate
	R4083, R4084	451630104 or 1Ω, 1W, Metal plate
	R4099, R4100	441621634 or 1Ω, 1W, Metal plate
	R4103, R4104	16KΩ, 1W, Metal oxide film
	R4121, R4124	820Ω, 1W, Metal oxide film
	R4125, R4128	4.7KΩ, 1W, Metal oxide film
		750Ω, 1/2W, Metal oxide film

PROTECTOR AND RECTIFIER PC BOARD VIEW FROM BOTTOM SIDE

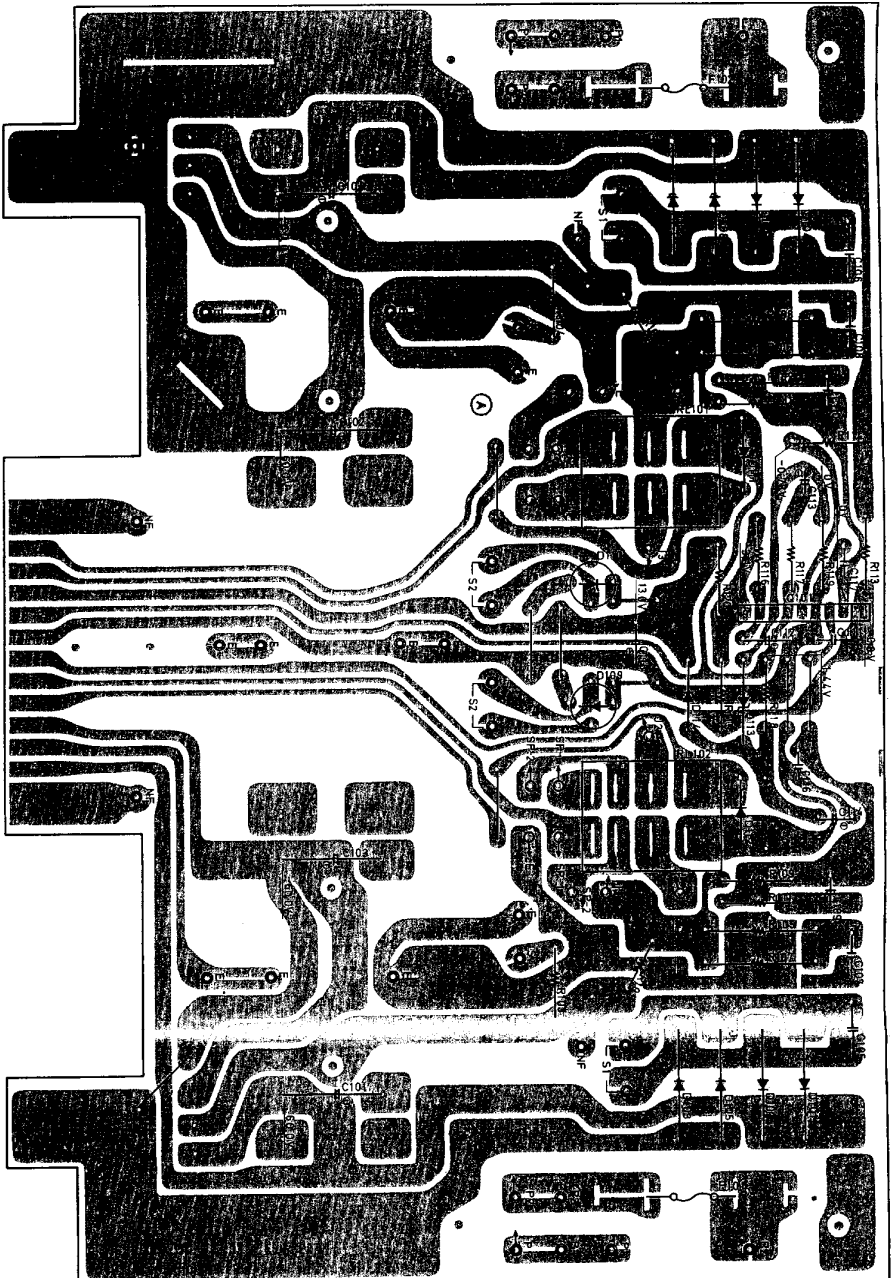

PROTECTOR AND RECTIFIER CIRCUIT PC BOARD (NAPS-749) - PARTS LIST
120V Model

CIRCUIT NO.	PARTS NO.	DESCRIPTION
Q101	IC	TA7317P
D101-D108	Diodes	GR-30G
D109, D110		W1.01
D111, D112		GR-08B or SR1K-2
D113		RD6.2E-B or 05Z6.2L
L101, L102	Coils	S-0-8D
C101-C104	Capacitors	CE62W69V18, 000X2, Elect.
C107, C108		374136835 0.068uF±10%, 100V, DE
C112		352732201 22uF, 10V, Elect

220V Model

CIRCUIT NO.	PARTS NO.	DESCRIPTION
C113	Resistors	352784791 0.47uF, 50V, Elect.
C114		352743311 330uF, 16V, Elect.
C115		352742221 2.200uF, 16V, Elect.
C116, C117		352922206 22uF, 6.3V, Non-polar elect.
C119, C120		384171037 0.01uF, 630V, DI
R101, R102	Resistors	451630684 6.8Ω, 1W, Metal
R105-R108		442722204F 22Ω, 2W, Metal oxide film
RL101	Relays	25063036 NRL-4P3ADC12-01
RL102		25065124 NRL-4P3ADC12-04
F101, F102	Fuseholder	250113 S-MS051
	Fuse	252050 5A, ST-6, Fuse

TA7317P block diagram

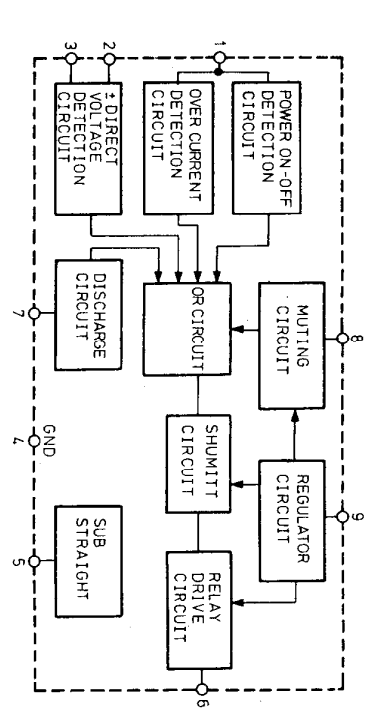

TA7318P block diagram

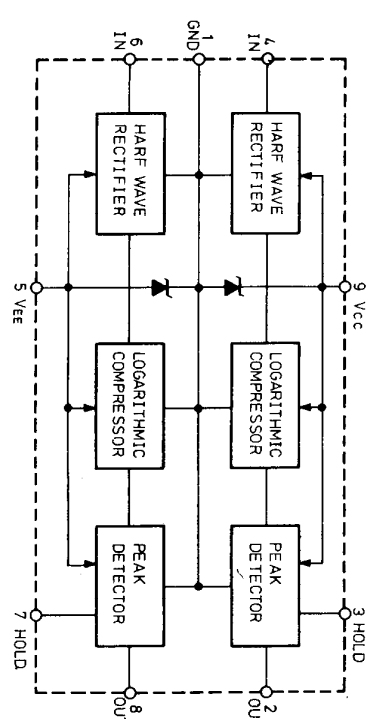

SWITCH CIRCUIT PC BOARD (NASW-754a) - PARTS LIST

CIRCUIT NO.	PARTS NO.	DESCRIPTION
R101, R102	Resistors	6.8Ω, 1W, Metal
R105-R108		442722204F 22Ω, 2W, Metal oxide film
RL101	Relays	25063036 NRL-4P3ADC12-01
RL102		25065124 NRL-4P3ADC12-04
L101, L102	Coils	S-0-8D
C101-C104	Capacitors	CE62W69V18, 000X2, Elect.
C107, C108		374136835 0.068uF±10%, 100V, DE
C112		352732201 22uF, 10V, Elect.
C113		352784791 0.47uF, 50V, Elect.
C114		352743311 330uF, 16V, Elect.
C115		352742221 2.200uF, 16V, Elect.
C116, C117		352922206 22uF, 6.3V, Non-polar elect.
C119, C120		384171037 0.01uF, 630V, DI
PL601	Lamps	PL14V0.06AW-3
PL602		PL14V0.06AW-1.5
R605, R606	Resistors	441521014 100Ω, 1/2W, Metal oxide film
S601	Switch	25035164 NSAS-3P028
		NPS-142-L128

METER DRIVE CIRCUIT PC BOARD VIEW FROM BOTTOM SIDE

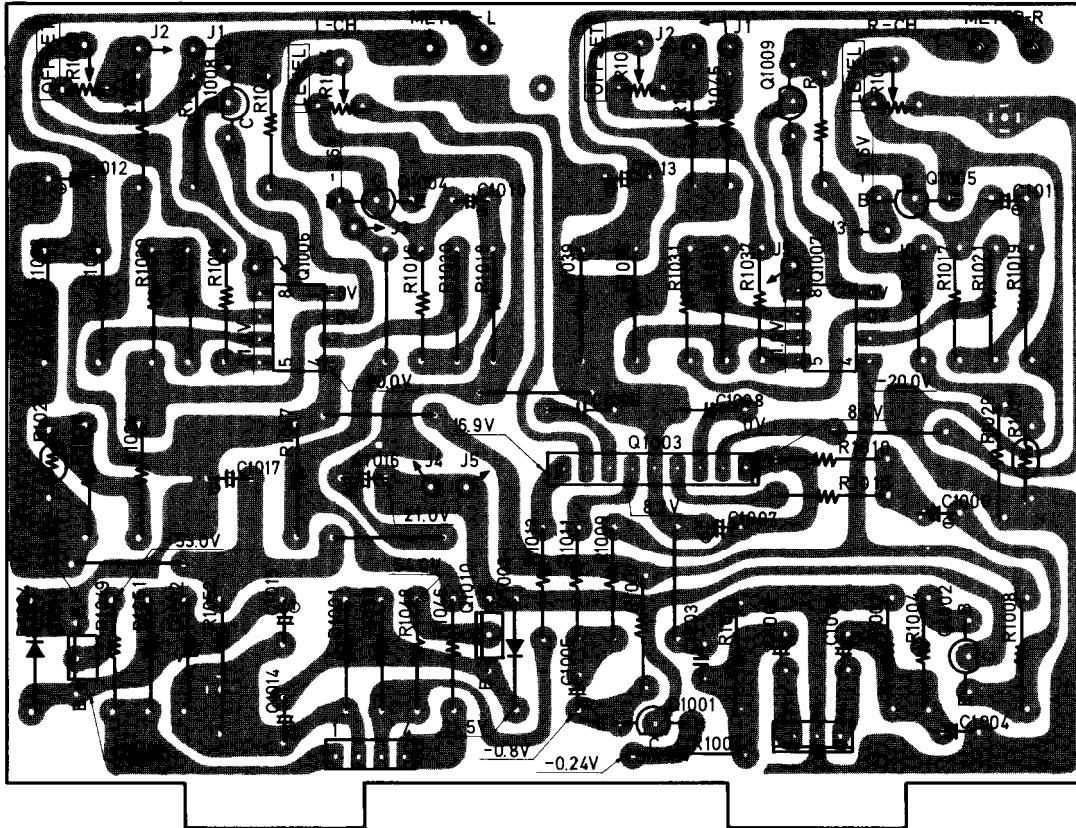

SPEAKER SELECTOR SWITCH PC BOARD (NASW-755b) – PARTS LIST

CIRCUIT NO.	PARTS NO.	DESCRIPTION
PL701, PL702	210084	PL14V0.06AW-1.5, lamp
R701	441521014	100Ω, 1/2W, Metal oxide film
S701, S702	25035165	NPS-222-L129, Switch

LAMP CIRCUIT PC BOARD (NAPL-756) – PARTS LIST

CIRCUIT NO.	PARTS NO.	DESCRIPTION
PL801–PL804	210038	PL12V150mA, lamp
R801	451631004	10Ω, 1W, Metal resistor
	27250021	Lamp case

LAMP CIRCUIT PC BOARD (NAPL-757) – PARTS LIST

CIRCUIT NO.	PARTS NO.	DESCRIPTION
PL901–PL904	210038	PL12V150mA, Lamp
R901	451631004	10Ω, 1W, Metal resistor
	27250021	Lamp case

METER DRIVE CIRCUIT PC BOARD (NAME-758) – PARTS LIST

CIRCUIT NO.	PARTS NO.	DESCRIPTION
	ICs	
Q1003	222531	TA-7318P(Y)
Q1006, Q1007	222502	NJM-4558DX
	Transistors	
Q1001, Q1002	2211255	2SC1815(GR)
Q1004, Q1005	2211255	2SC1815(GR)
Q1010	2200744	2SD526(Y)
Q1011	2200413	2SB596(Y)
	Diodes	
D1001, D1002	223974	RD20EC
D1003, D1004	223105	1S1555
D1005–D1007	223915	WZ-150
D1008, D1009	223105	1S1555
	Capacitors	
C1001, C1002	352780101	1μF, 50V, Elect.
C1005, C1006	352780331	3.3μF, 50V, Elect.
C1007	352780101	1μF, 50V, Elect.
C1008, C1009	374122735	0.027μF±10%, 50V, DE
C1010, C1011	352780331	3.3μF, 50V, Elect.
C1012–C1015	352754701	47μF, 25V, Elect.
C1016, C1017	352752211	220μF, 25V, Elect.
	Resistors	
R1013	441622724	2.7kΩ, 1W, Metal oxide film
R1014, R1015	5221023	N10HR470BEM, Semi-fixed
R1026, R1027	4000028	D-33A, Thermistor
R1040, R1041	5221023	N10HR470BEM, Semi-fixed
R1048, R1049	442523014	300Ω, 1/2W, Metal oxide film
R1051, R1050	442525124	5.1kΩ, 1/2W, Metal oxide film
	Plug	
	25065095	NPLG-3P17

PACKING PROCEDURES

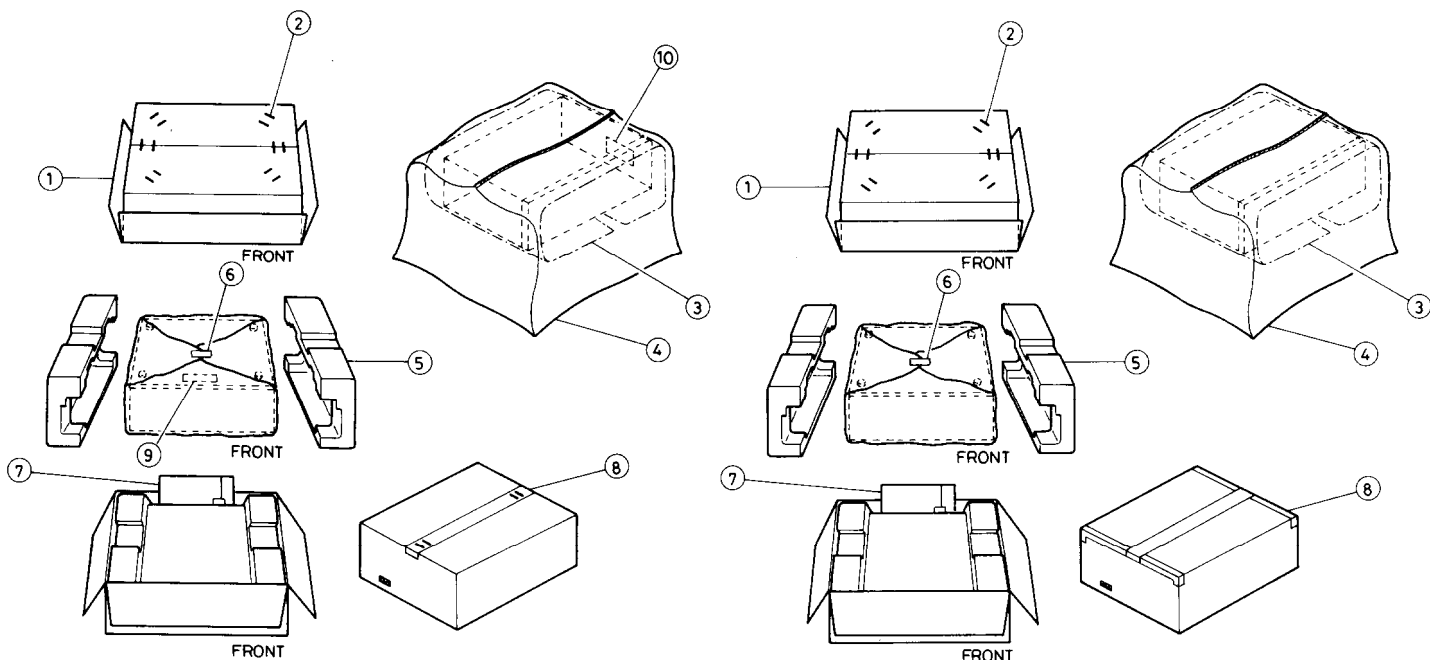

PACKING PROCEDURES – PARTS LIST 120V Model

REF. NO.	PARTS NO.	DESCRIPTION
1	29050375	Master carton box
2	282301	Sealing hook
3	290008-1	500×1,000mm, Protection sheet
4	29100034	650×850mm, Poly bag
5	29090527	Pad
6	261504	30×10mm, Tape
7	2010069	Connection cord
	29340434	Instruction manual
	29365006	Warranty card (Only U.S.A. model)
	29358002	Service Station list (Only U.S.A. model)
	29100005	220×330mm, Poly bag
8	260012	50×1000mm, Tape
9	29360363	Caution label (Only U.S.A. model)
10	29355059	Label (Only U.S.A. model)

PACKING PROCEDURES – PARTS LIST 220V Model

REF. NO.	PARTS NO.	DESCRIPTION
1	29050375	Master carton box
2	282301	Sealing hook
3	290008-1	500×1,000mm, Protection sheet
4	29100034	650×850mm, Poly bag
5	29090527	Pad
6	261504	30×10mm, Tape
7	2010069	Connection cord
	29340435	Instruction manual
	29365005-2	Warranty card (Only Germany model)
	29100005	220×330mm, Poly bag
8	260012	50×1000mm, Tape

ONKYO CORPORATION

International Division : No. 24 Mori Bldg., 23-5, 3-chome, Nishi-Shinbashi, Minato-ku, Tokyo, Japan
Telex : 2423551 ONKYO J. Phone : 03-432-6981

ONKYO U.S.A. CORPORATION

Eastern Office
42-07 20th Avenue, Long Island City, New York 11105, U.S.A. Phone : (212) 728-4639
Midwest Office
935 Sivert Drive, Wooddale, Illinois 60191, U.S.A. Phone : (312) 595-2970
C/O Damark Industries Inc.
20520 Nordhoff Chatsworth, Cal. 91311, U.S.A. Phone : (213) 998-6501

ONKYO DEUTSCHLAND GMBH, ELECTRONICS

8034 München-Germering, Industriestrasse 18, West Germany. Telex : 521726 Telefon : (089)-845-5041