

Service Manual

PIONEER
The Art of Entertainment

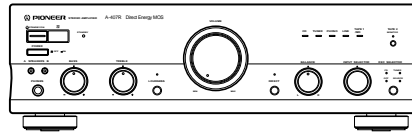

ORDER NO.
RRV1958

STEREO AMPLIFIER A-407R

THIS MANUAL IS APPLICABLE TO THE FOLLOWING MODEL(S) AND TYPE(S).

Type	Model	Power Requirement	Remarks
	A-407R		
MY/EW	○	AC220 – 230V	
MY/GR	○	AC220 – 230V	
MV	○	AC220 – 230V	

CONTENTS

1. SAFETY INFORMATION	2	7. GENERAL INFORMATION	23
2. EXPLODED VIEWS AND PARTS LIST	3	7.1 IC INFORMATION	23
3. SCHEMATIC DIAGRAM	6	7.2 BLOCK DIAGRAM	24
4. PCB CONNECTION DIAGRAM	14	8. PANEL FACILITIES AND SPECIFICATIONS	25
5. PCB PARTS LIST	19		
6. ADJUSTMENT	22		

PIONEER ELECTRONIC CORPORATION 4-1, Meguro 1-Chome, Meguro-ku, Tokyo 153-8654, Japan
PIONEER ELECTRONICS SERVICE, INC. P.O. Box 1760, Long Beach, CA 90801-1760, U.S.A.
PIONEER ELECTRONIC (EUROPE) N.V. Haven 1087, Keetberglaan 1, 9120 Melsele, Belgium
PIONEER ELECTRONICS ASIACENTRE PTE. LTD. 501 Orchard Road, #10-00 Wheelock Place, Singapore 238880
 © PIONEER ELECTRONIC CORPORATION 1998

T - IZK MAY 1998 Printed in Japan

1. SAFETY INFORMATION

This service manual is intended for qualified service technicians ; it is not meant for the casual do-it-yourselfer. Qualified technicians have the necessary test equipment and tools, and have been trained to properly and safely repair complex products such as those covered by this manual.

Improperly performed repairs can adversely affect the safety and reliability of the product and may void the warranty. If you are not qualified to perform the repair of this product properly and safely, you should not risk trying to do so and refer the repair to a qualified service technician.



WARNING

Lead in solder used in this product is listed by the California Health and Welfare agency as a known reproductive toxicant which may cause birth defects or other reproductive harm (California Health & Safety Code, Section 25249.5).

When servicing or handling circuit boards and other components which contain lead in solder, avoid unprotected skin contact with the solder. Also, when soldering do not inhale any smoke or fumes produced.



NOTICE

(FOR CANADIAN MODEL ONLY)

Fuse symbols  (fast operating fuse) and/or  (slow operating fuse) on PCB indicate that replacement parts must be of identical designation.

REMARQUE

(POUR MODÈLE CANADIEN SEULEMENT)

Les symboles de fusible  (fusible de type rapide) et/ou  (fusible de type lent) sur CCI indiquent que les pièces de remplacement doivent avoir la même désignation.

(FOR USA MODEL ONLY)

1. SAFETY PRECAUTIONS

The following check should be performed for the continued protection of the customer and service technician.

LEAKAGE CURRENT CHECK

Measure leakage current to a known earth ground (water pipe, conduit, etc.) by connecting a leakage current tester such as Simpson Model 229-2 or equivalent between the earth ground and all exposed metal parts of the appliance (input/output terminals, screwheads, metal overlays, control shaft, etc.). Plug the AC line cord of the appliance directly into a 120V AC 60Hz outlet and turn the AC power switch on. Any current measured must not exceed 0.5mA.

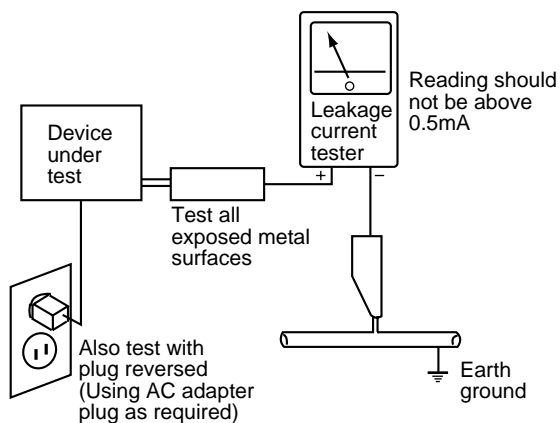

AC Leakage Test

ANY MEASUREMENTS NOT WITHIN THE LIMITS OUTLINED ABOVE ARE INDICATIVE OF A POTENTIAL SHOCK HAZARD AND MUST BE CORRECTED BEFORE RETURNING THE APPLIANCE TO THE CUSTOMER.

2. PRODUCT SAFETY NOTICE

Many electrical and mechanical parts in the appliance have special safety related characteristics. These are often not evident from visual inspection nor the protection afforded by them necessarily can be obtained by using replacement components rated for voltage, wattage, etc. Replacement parts which have these special safety characteristics are identified in this Service Manual.

Electrical components having such features are identified by marking with a Δ on the schematics and on the parts list in this Service Manual.

The use of a substitute replacement component which does not have the same safety characteristics as the PIONEER recommended replacement one, shown in the parts list in this Service Manual, may create shock, fire, or other hazards.

Product Safety is continuously under review and new instructions are issued from time to time. For the latest information, always consult the current PIONEER Service Manual. A subscription to, or additional copies of, PIONEER Service Manual may be obtained at a nominal charge from PIONEER.

2. EXPLODED VIEWS AND PARTS LIST

- NOTES:
- Parts marked by "NSP" are generally unavailable because they are not in our Master Spare Parts List.
 - The Δ mark found on some component parts indicates the importance of the safety factor of the part. Therefore, when replacing, be sure to use parts of identical designation.
 - Screws adjacent to ∇ mark on the product are used for disassembly.

2.1 PACKING

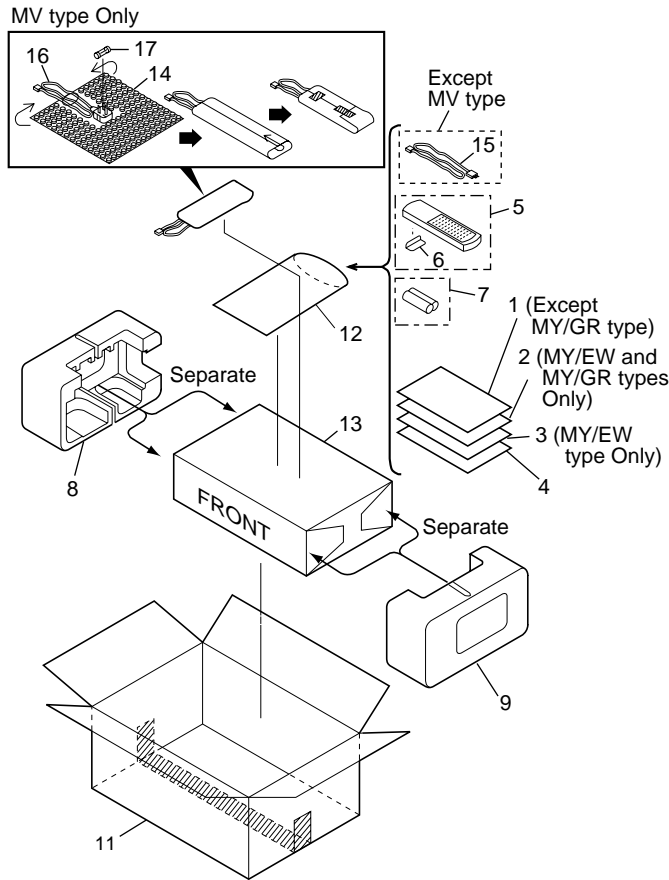

(1) PACKING PARTS LIST

Mark	No.	Description	Part No.
	1	Operating Instructions (English)	See Contrast table(2)
	2	Operating Instructions (German)	See Contrast table(2)
	3	Operating Instructions (French/Italian/Dutch/Swedish/Spanish/Portugese)	See Contrast table(2)
NSP	4	Warranty Card	ARY7008
	5	Remote Control Unit (CU-A013)	AXD7164
NSP	6	Battery Cover	AZN2249
	7	Dry Cell Battery (R6P,AA)	AEX-010
	8	Side Protector L	AHA7127
	9	Side Protector R	AHA7128
	10	•••••	
	11	Packing Case	AHD7565
NSP	12	Literature Bag	AHG-117
	13	Packing Sheet	AHG1016
NSP	14	Air Cap	See Contrast table(2)
Δ	15	Power Cord	See Contrast table(2)
Δ	16	Power Cord with Fuse	See Contrast table(2)
Δ	17	Fuse (T5A)	See Contrast table(2)

(2) CONTRAST TABLE

A-407R/MY/EW, MY/GR and MV are constructed the same except for the following :

Mark	No.	Symbol and Description	Part No.			Remarks
			MY/EW Type	MY/GR Type	MV Type	
	1	Operating Instructions (English)	ARB7139	Not used	ARB7139	
	2	Operating Instructions (German)	ARC7187	ARC7187	Not used	
	3	Operating Instructions (French/Italian/Dutch/Swedish/Spanish/Portuguese)	ARC7188	Not used	Not used	
NSP	14	Air Cap	Not used	Not used	AHG1087	
Δ	15	Power Cord	ADG1154	ADG1154	Not used	
Δ	16	Power Cord with Fuse	Not used	Not used	ADG1156	
Δ	17	Fuse (T5A)	Not used	Not used	AEK1046	

2.2 EXTERIOR

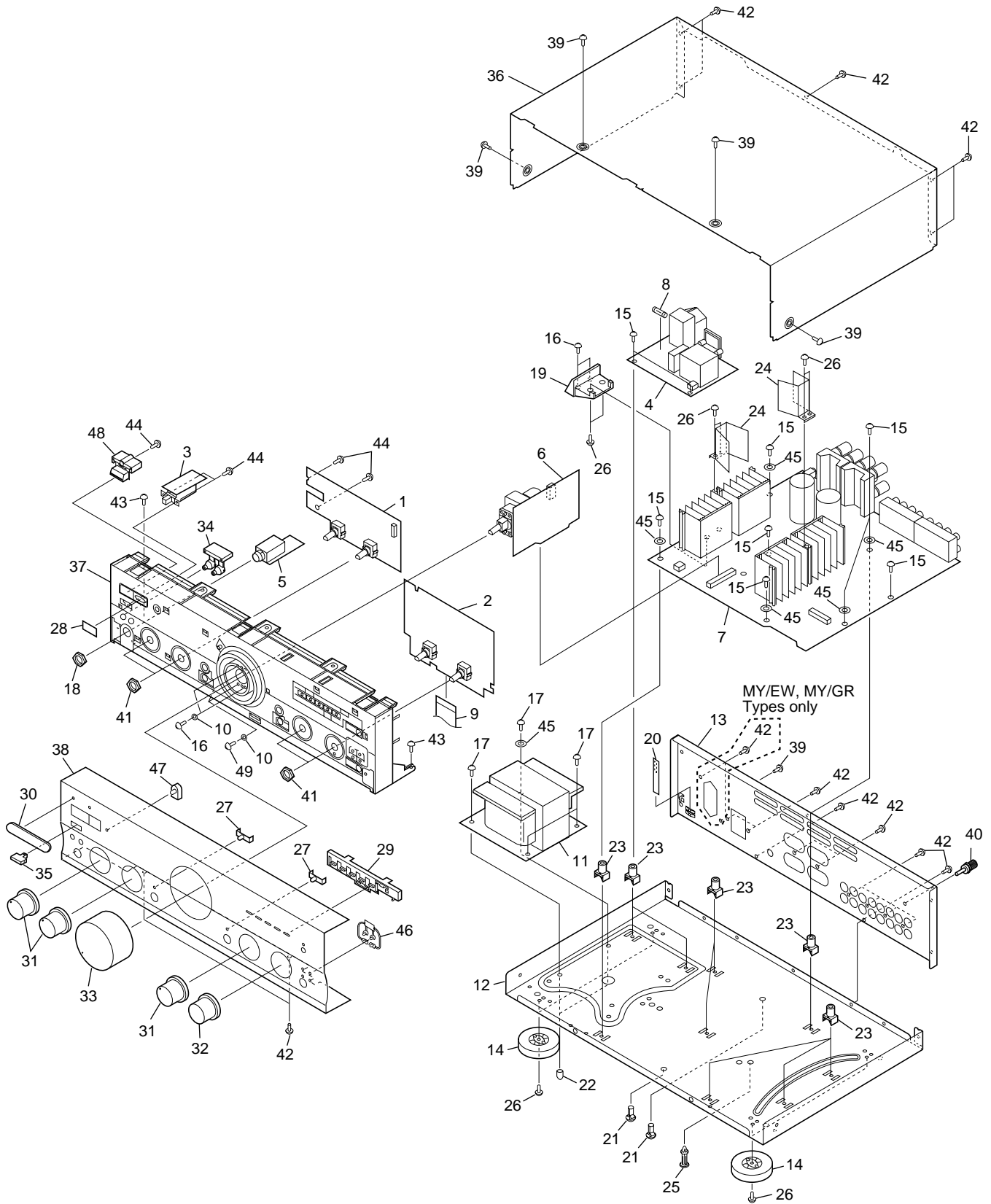

(1) EXTERIOR PARTS LIST

Mark	No.	Description	Part No.	Mark	No.	Description	Part No.
	1	FRONT L Assy	AWX7054		26	Screw	ABA-298
	2	FRONT R Assy	AWX7050		27	LED Lens	AAK2459
	3	POWER SW Assy	AWX7057		28	IR Filter	AAK7532
	4	AC PRIMARY Assy	See Contrast table(2)		29	LED Lens T	AAK7544
NSP	5	HEADPHONE Assy	AWX7052		30	Name Plate	AAM7004
	6	VOLUME Assy	AWX7055		31	Rotary Knob A	AAB7148
	7	AF Assy	AWX7053		32	Rotary Knob B	AAB7149
△	8	Fuse (FU1, T2A L250V)	AEK1057		33	Volume Knob	AAB7147
	9	Flexible Cable (J1, 21P) (AF CN202 - FRONT R CN601)	ADD1114		34	Speaker Button	AAD7435
	10	Washer	ABE1002		35	Main Power Button	AAD7437
△	11	Power Transformer (T1)	ATS7202		36	Bonnet Case	ANE7185
NSP	12	Chassis	ANA7048		37	Panel Base	AMB7484
	13	Rear Panel	See Contrast table(2)		38	Front Panel	ANB7112
	14	Insulator	PNW2766		39	Screw	BBT30P080FZK
	15	Screw	ABA1018		40	Terminal Screw	AKE-031
	16	Screw	ABA1050		41	Nut	NK90FUC
	17	Screw (4 × 10)	ABA7047		42	Screw	ABA1006
	18	Nut	ABN-065		43	Screw	ABA1009
NSP	19	PCB Mold	AMR7222		44	Screw	BPZ30P080FMC
	20	Barrier	AEC7072		45	Washer	WG40FCC
NSP	21	PCB Holder	AEC7057		46	LED Lens B	AAK7538
	22	Stud Cover	AEC7096		47	LED Lens	PNW2019
NSP	23	PCB Mold	AMR1525		48	Power Button	AAD7436
NSP	24	Radiator Plate B	AMR7223		49	Screw	BMZ30P080FCU
	25	Locking Card Spacer	DEC1908				

(2) CONTRAST TABLE

A-407R/MY/EW, MY/GR and MV are constructed the same except for the following :

Mark	No.	Symbol and Description	Part No.			Remarks
			MY/EW Type	MY/GR Type	MV Type	
	4	AC PRIMARY Assy	AWX7051	AWX7051	AWX7056	
	13	Rear Panel	ANC7646	ANC7646	ANC7660	

Note : When ordering service parts, be sure to refer to "EXPLODED VIEWS and PARTS LIST" or "PCB PARTS LIST".

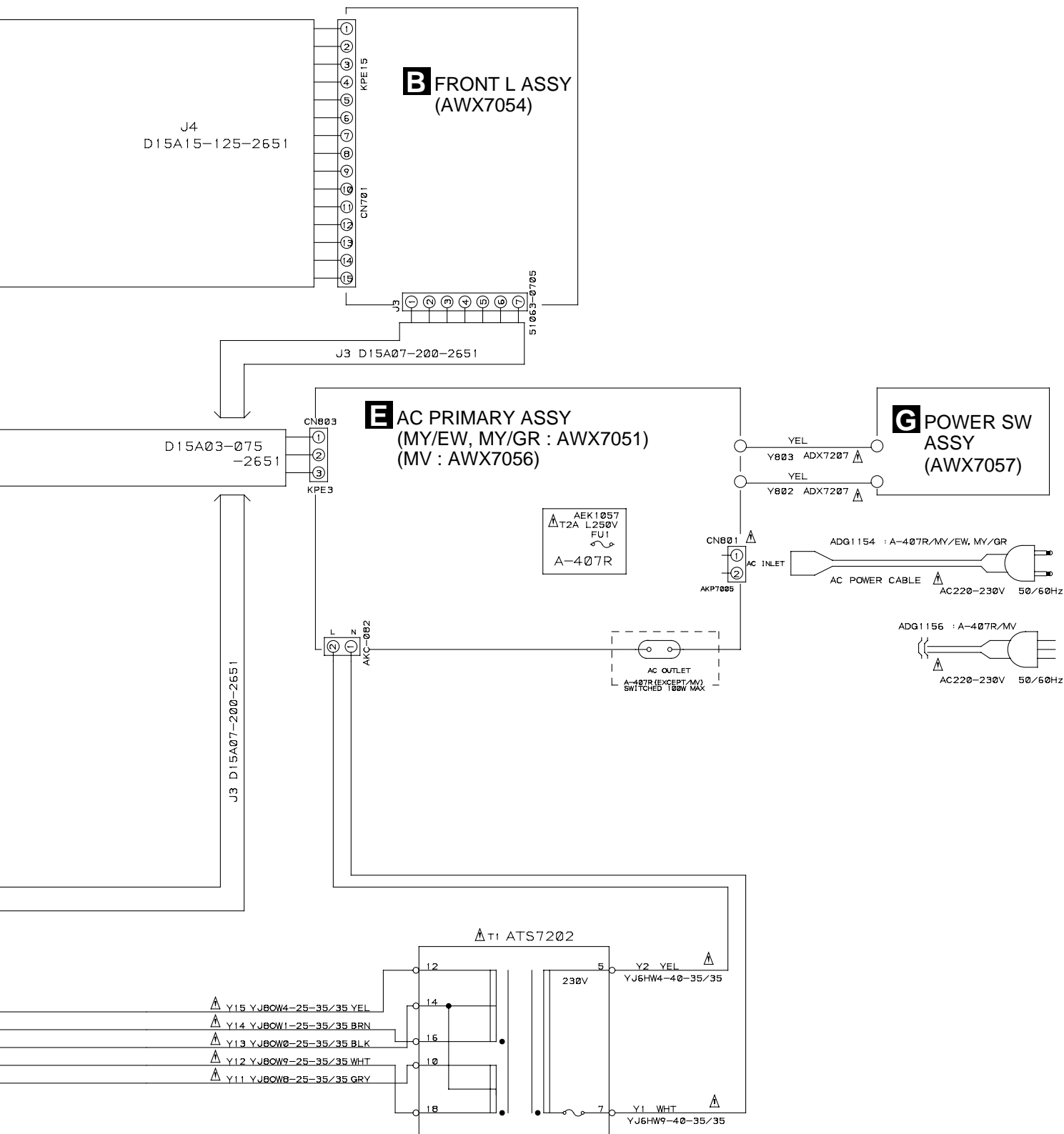

A

B

C

D

D CN601

E CN803

A AF ASSY (AWX7053)

TO POWER TRANSFORMER T1

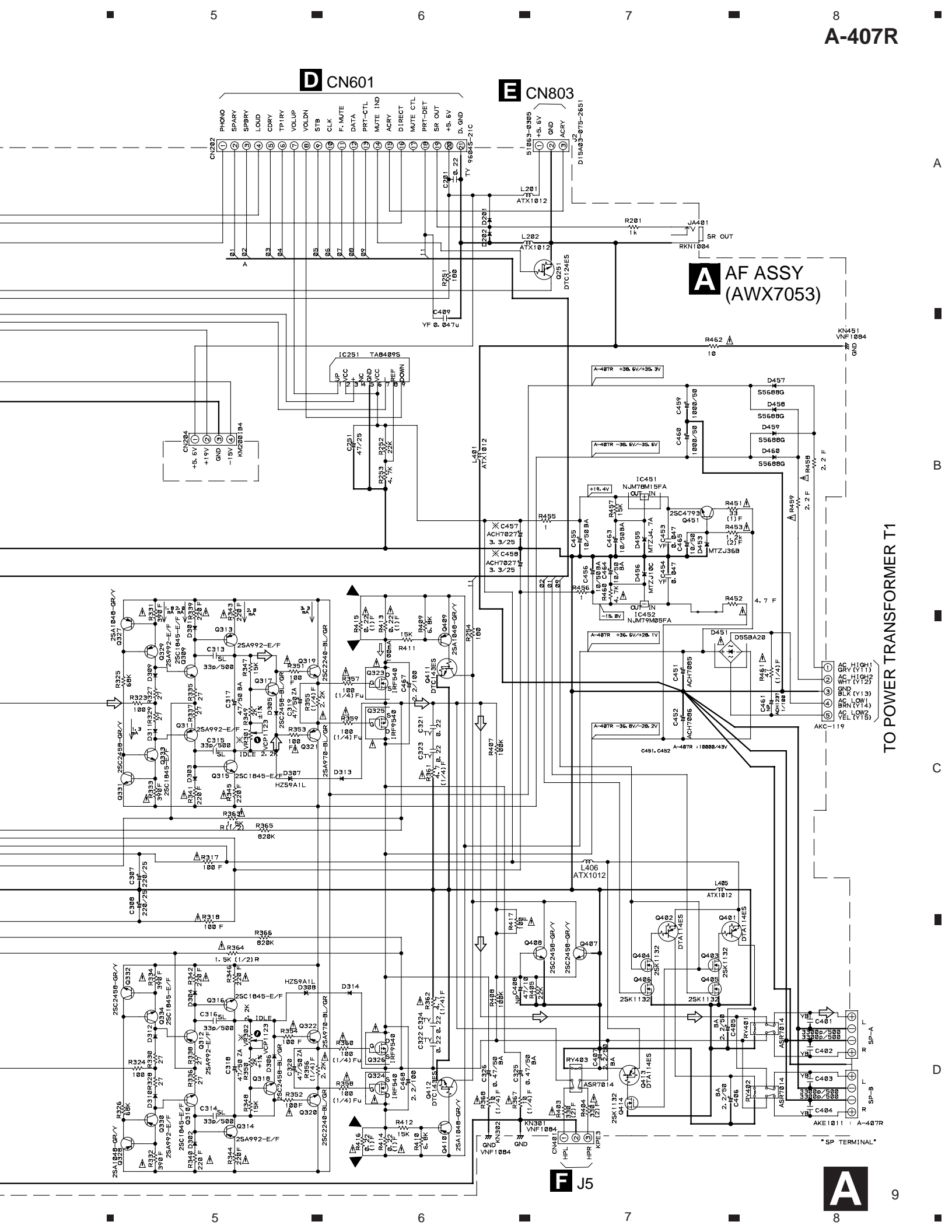

A
B
C
D
9



F J5

SP TERMINAL

3.3 FRONT L AND VOLUME ASSEMBLIES

A

B

C

D

B FRONT L ASSY (AWX7054)

FRONT L ASSY
 S 701 : POWER STANDBY/ON
 S 702 : LOUDNESS
 S 703 : SPEAKERS A
 S 704 : SPEAKERS B

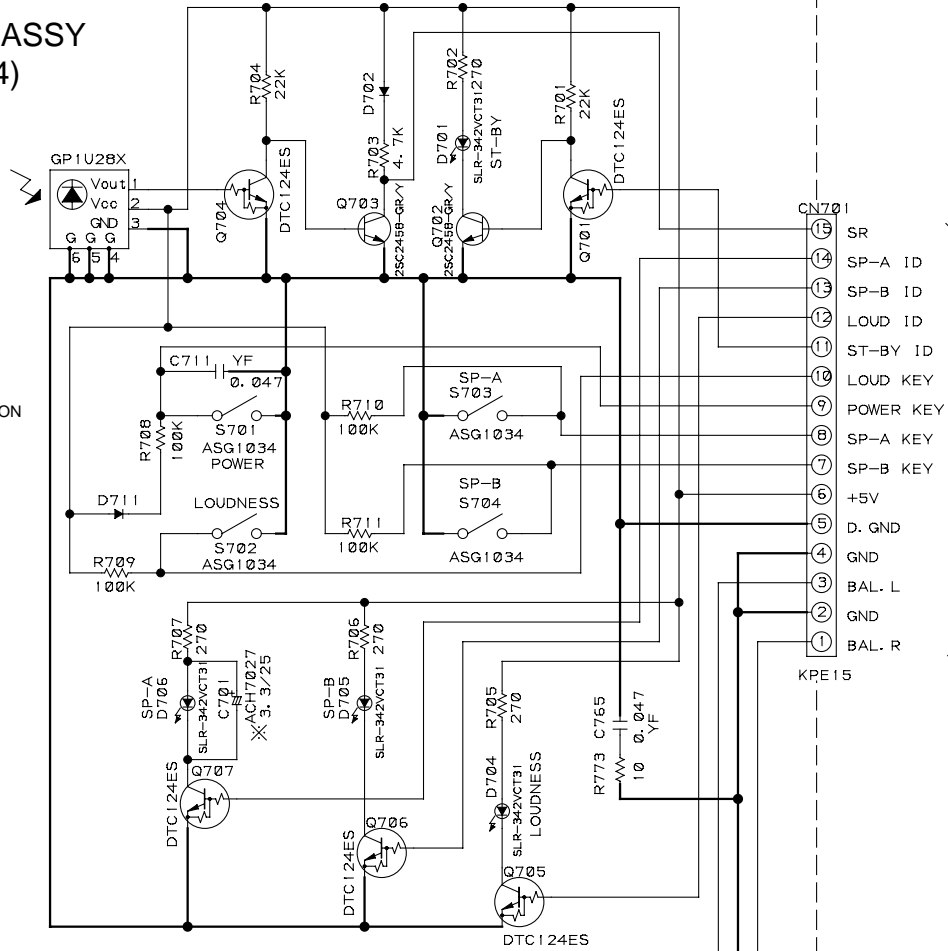

- 15 SR
 14 SP-A ID
 13 SP-B ID
 12 LOUD ID
 11 ST-BY ID
 10 LOUD KEY
 9 SP-A KEY
 8 SP-B KEY
 7 +5V
 6 D. GND
 5 GND
 4 BAL. L
 3 GND
 2 BAL. R
 1 KPE15

D J4

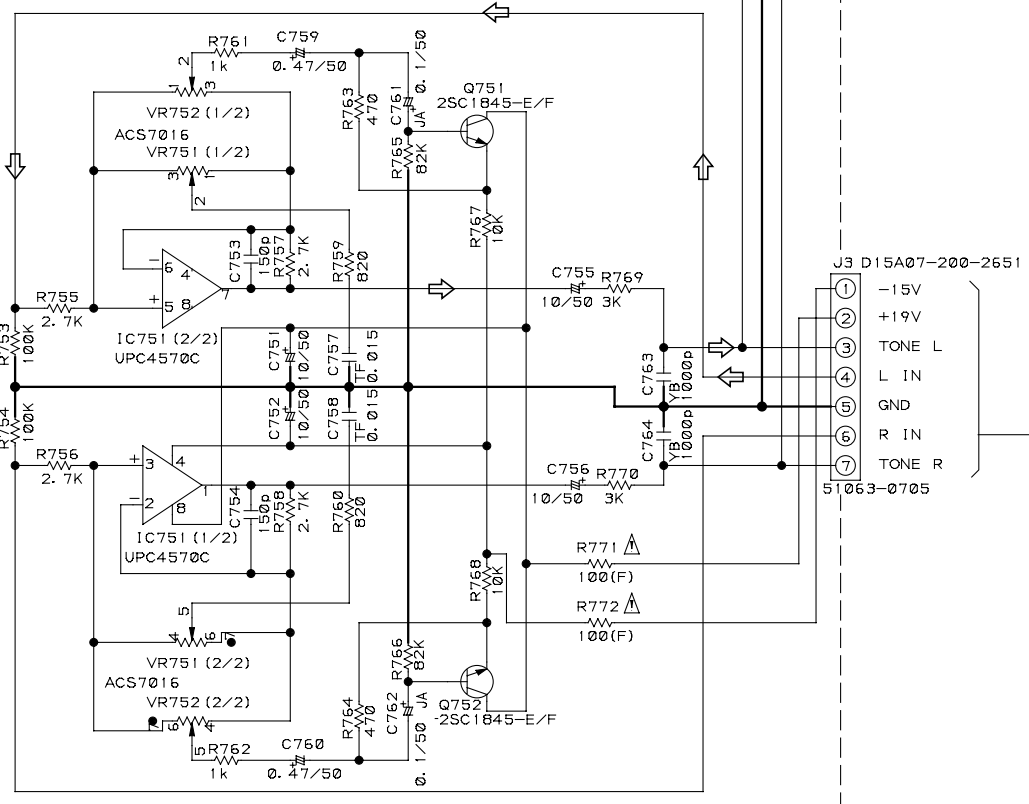

- 7 J3 D15A07-200-2651
 6 -15V
 5 +19V
 4 TONE L
 3 L IN
 2 GND
 1 R IN
 51063-0705

C VOLUME ASSY (AWX7055)

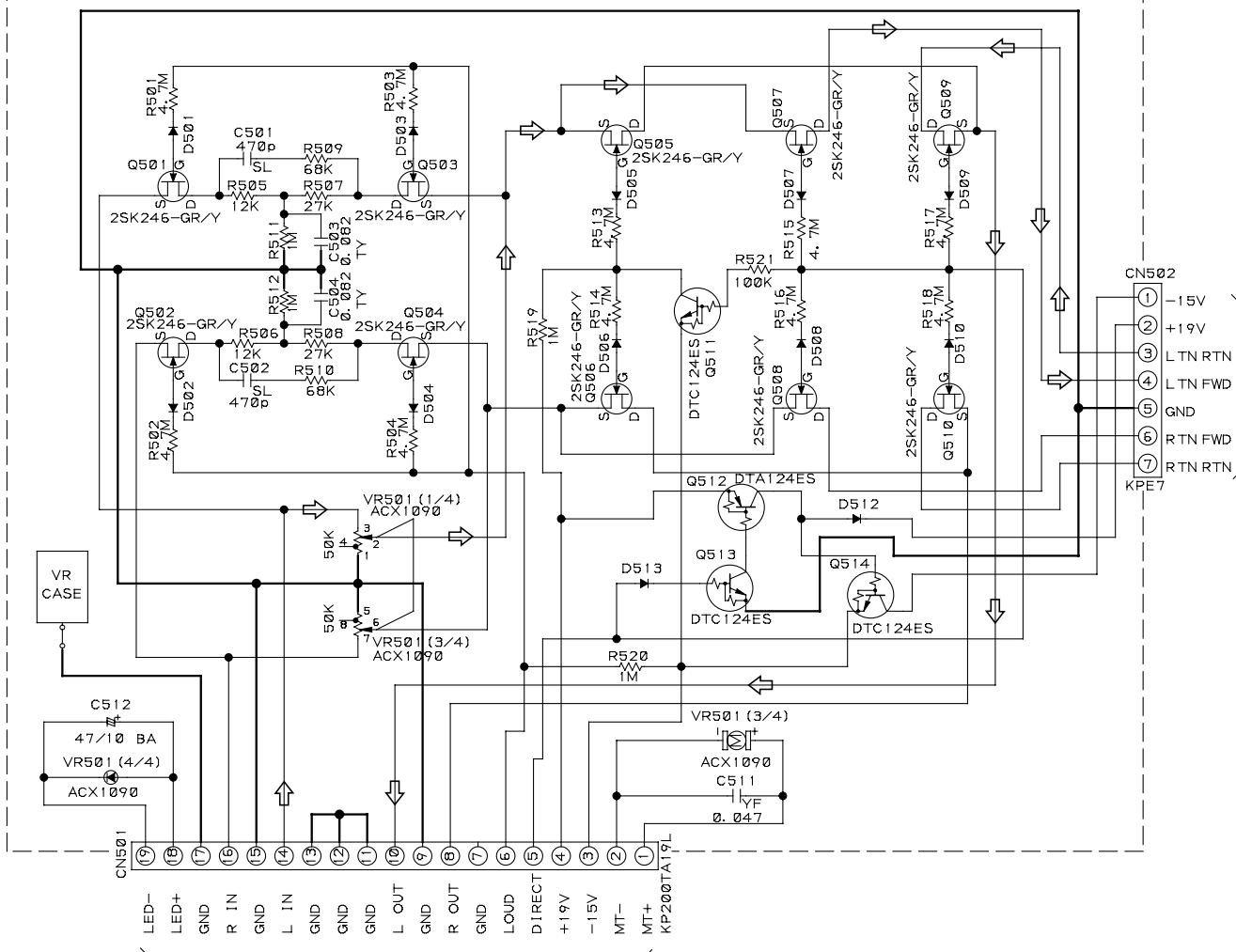

A CN203

↪ : AUDIO SIGNAL ROUTE

NOTES

- RESISTORS
INDICATED IN Ohm 1/4W±5% TOLERANCE UNLESS OTHERWISE NOTED K:Kohm
F, FL:NON-FRAMABLE TYPE
- CAPACITORS
INDICATED IN CAPACITY (uF)/VOLTAGE (V) UNLESS OTHERWISE NOTED p:pF
INDICATED WITHOUT VOLTAGE IS 50V EXCEPT ELECTROLYTIC CAPACITOR.
TF:CTLA TY:CTYA
JA:CEJA BA:CEBA
- DIODES
NO MARK DIODES ARE HSS104-02



3.4 FRONT R, AC PRIMARY, HEADPHONE AND POWER SW ASSEMBLIES

A

E AC PRIMARY ASSY (MY/EW, MY/GR : AWX7051) (MV : AWX7056)

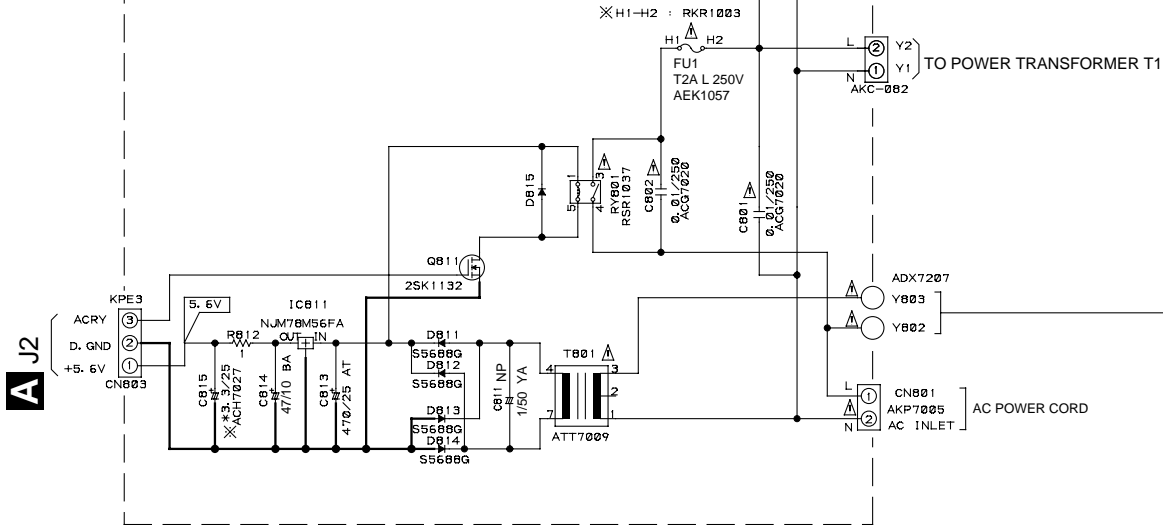

• NOTE FOR FUSE REPLACEMENT
CAUTION -FOR CONTINUED PROTECTION AGAINST RISK OF FIRE.
 REPLACE WITH SAME TYPE AND RATINGS ONLY.

B

C

D FRONT R ASSY (AWX7050)

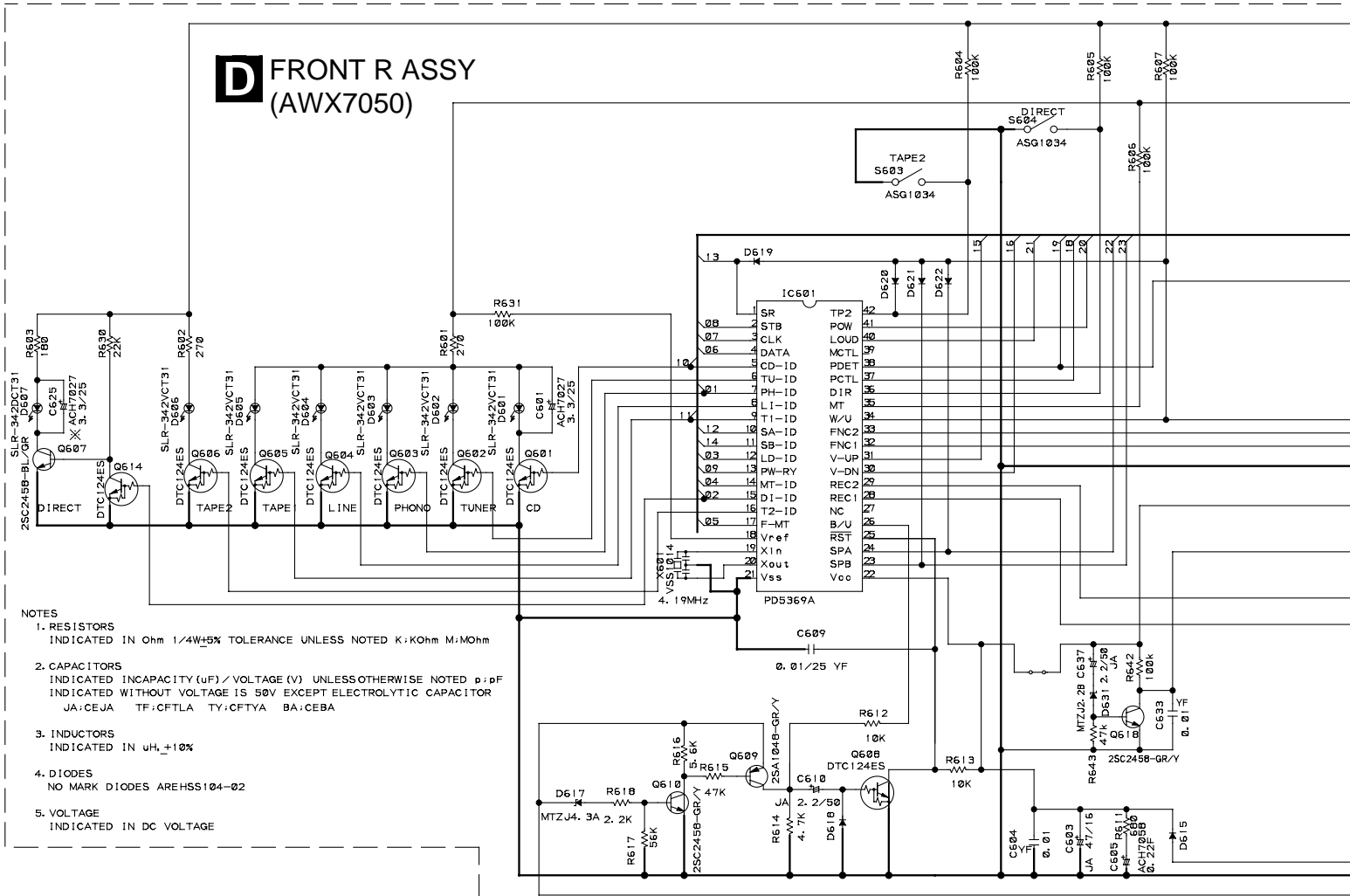

- NOTES
1. RESISTORS INDICATED IN Ohm 1/4W+5% TOLERANCE UNLESS NOTED K:KOhm M:MOhm
 2. CAPACITORS INDICATED IN CAPACITY (uF) / VOLTAGE (V) UNLESS OTHERWISE NOTED p:pF INDICATED WITHOUT VOLTAGE IS 50V EXCEPT ELECTROLYTIC CAPACITOR JA:CEJA TF:CFTLA TY:CFTYA BA:CEBA
 3. INDUCTORS INDICATED IN uH,+10%
 4. DIODES NO MARK DIODES AREHSS104-02
 5. VOLTAGE INDICATED IN DC VOLTAGE



G POWER SW ASSY (AWX7057)

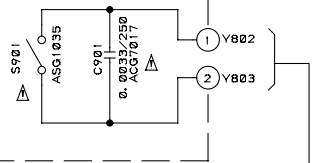

F HEADPHONE ASSY (AWX7052)

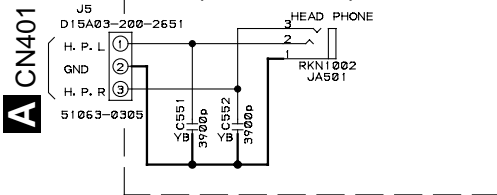

FRONT R ASSY
 S 601 : INPUT SELECTOR
 S 603 : TAPE2 MONITOR
 S 604 : DIRECT

 S 606 : REC SELECTOR

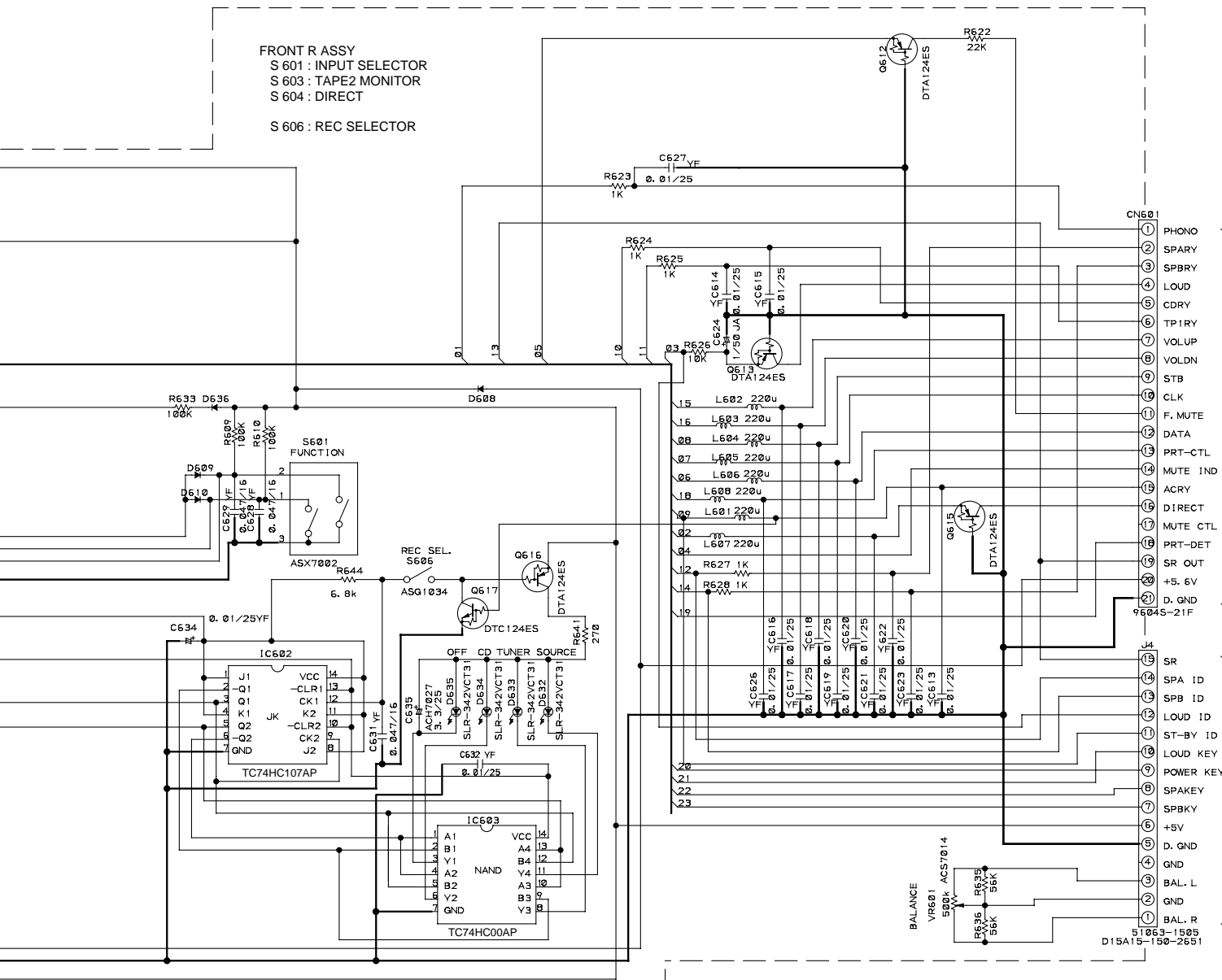

A CN202

B CN701



4. PCB CONNECTION DIAGRAM

4.1 AF ASSY

A
AF ASSY

POWER TRANSFORMER T1

E
CN803

NOTE FOR PCB DIAGRAMS:

1. Part numbers in PCB diagrams match those in the schematic diagrams.
2. A comparison between the main parts of PCB and schematic diagrams is shown below.

Symbol in PCB Diagrams	Symbol in Schematic Diagrams	Part Name
		Transistor
		Transistor with resistor
		Field effect transistor
		MOS Field effect transistor
		Resistor array
		3-terminal regulator

3. The parts mounted on this PCB include all necessary parts for several destination. For further information for respective destinations, be sure to check with the schematic diagram.
4. Viewpoint of PCB diagrams

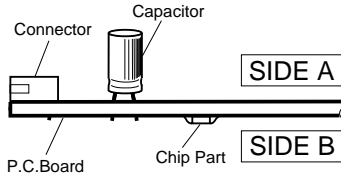

A
SIDE A

C
CN501

F
J5

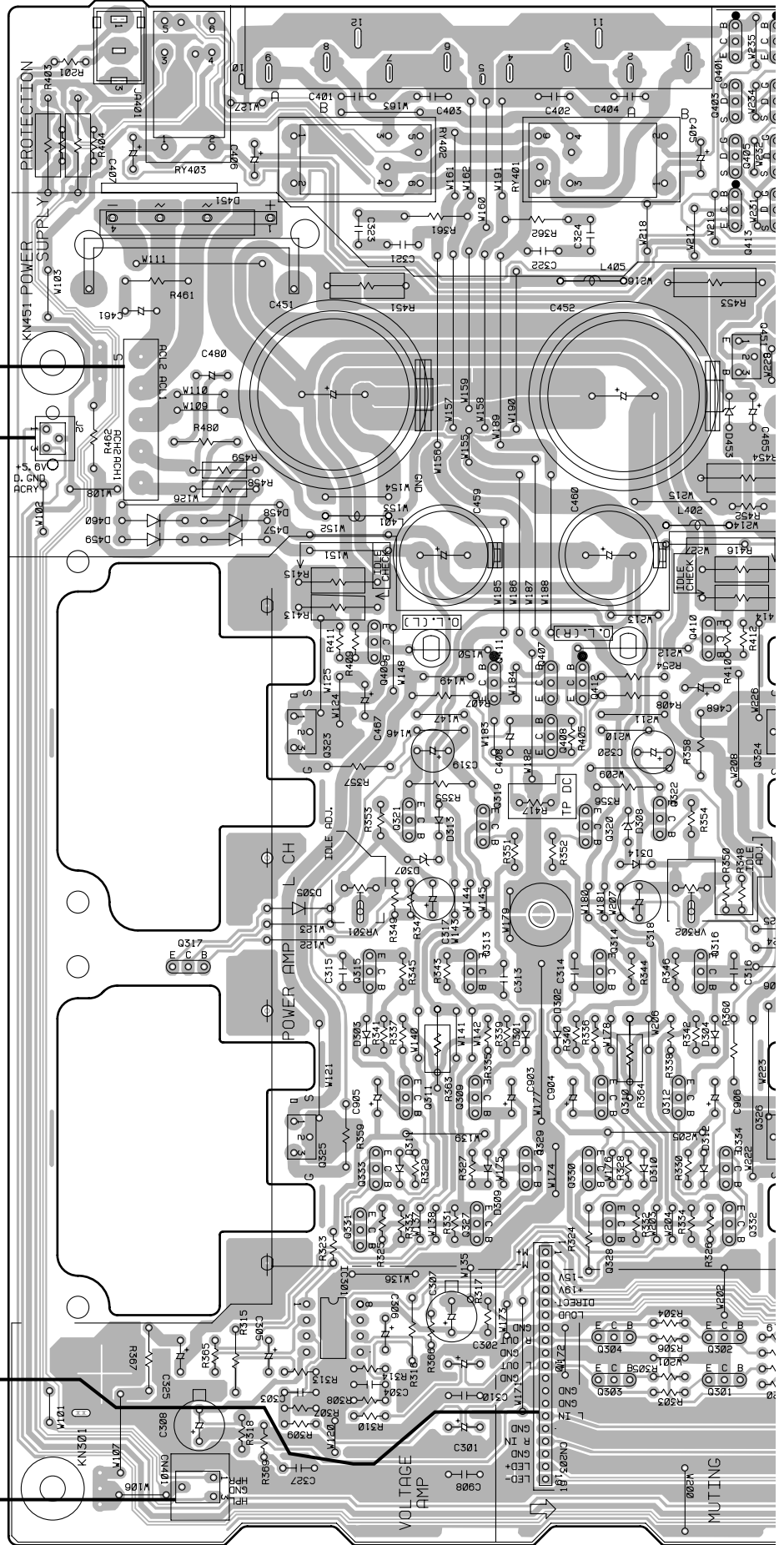

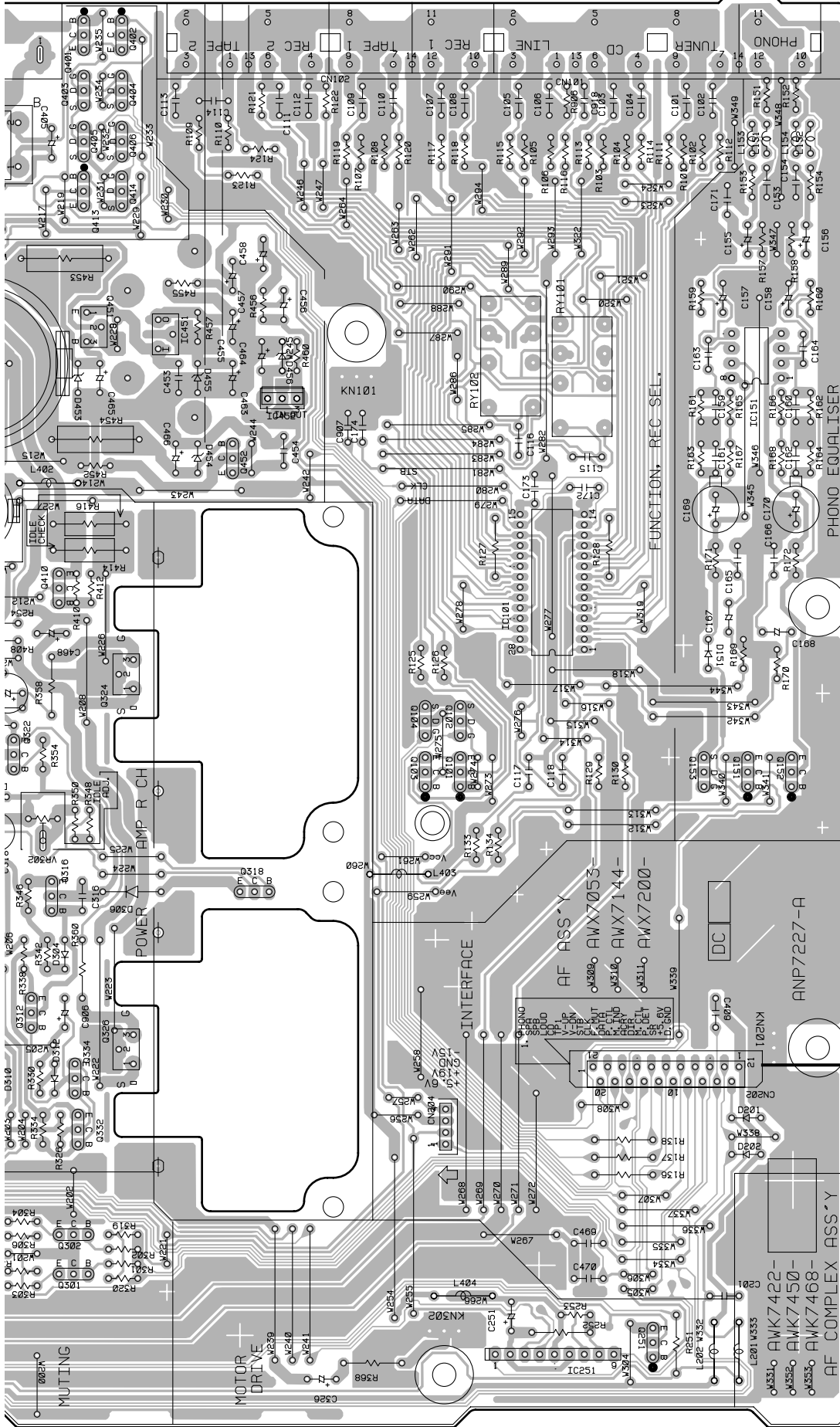

- Q401
- Q406
- Q413 Q414
- Q451 IC451 IC151 IC452
- Q452
- IC101
- Q409 Q410 Q411 Q407 Q412 Q323 Q408 Q324
- Q319 Q101 Q151 Q322 Q104 Q153
- VR301 VR302
- Q313 Q318
- D** CN601
- Q309 Q312 Q325
- Q334
- IC301 Q301 Q304
- IC251 Q251

(ANP7227-A)



4.2 FRONT L AND VOLUME ASSEMBLIES

B FRONT L ASSY

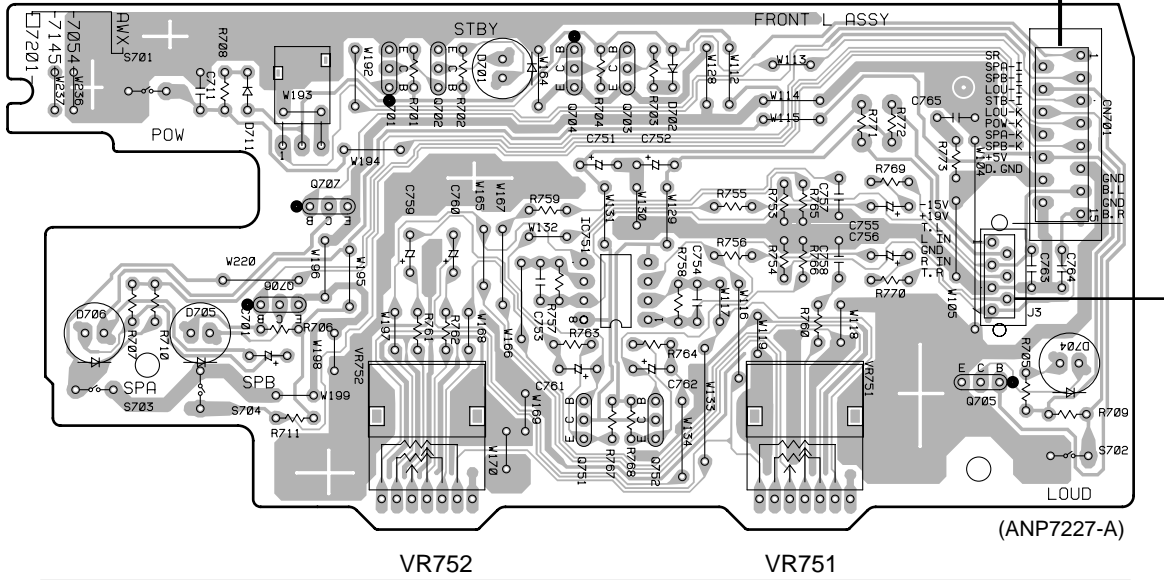

Q707
Q701 Q702 Q704 Q703
IC751
Q751 Q752
Q705
Q706

SIDE A

Q502
Q501
Q503
Q507
Q509
Q506 Q505
Q504
Q510
Q508
Q513
Q511
Q512
Q514

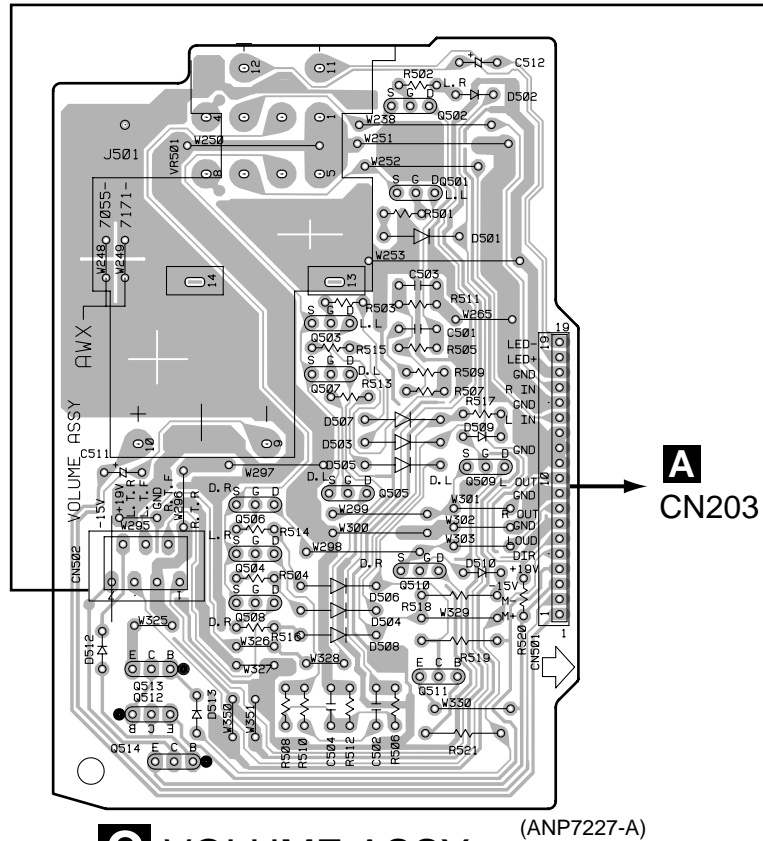

C VOLUME ASSY

4.3 FRONT R ASSY

D FRONT R ASSY

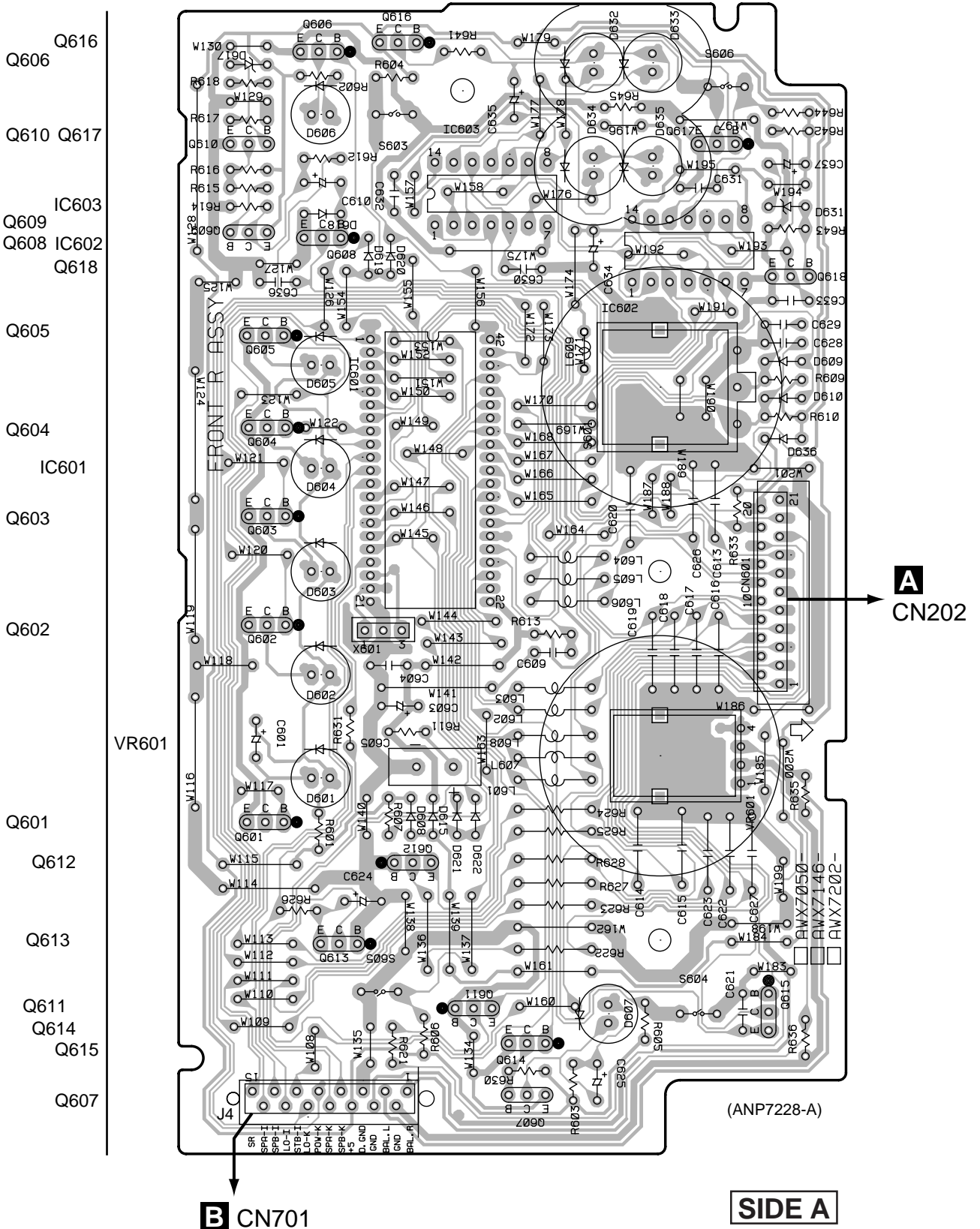

B CN701

SIDE A

A CN202

D

4.4 AC PRIMARY, HEADPHONE AND POWER SW ASSEMBLIES

F HEADPHONE ASSY

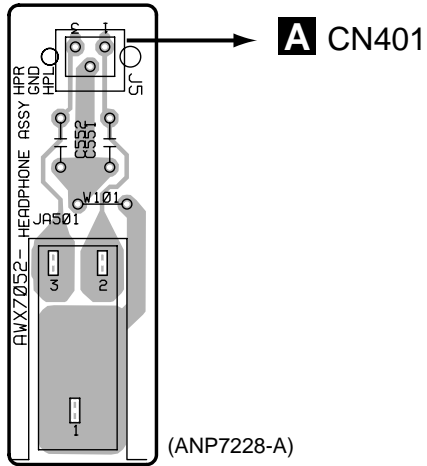

G POWER SW ASSY

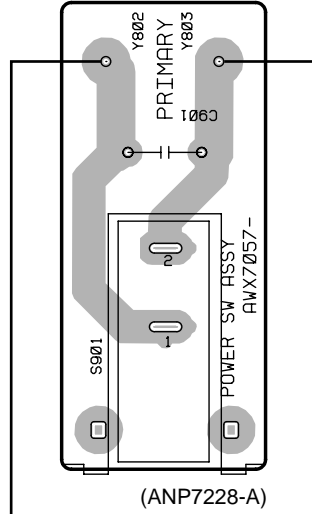

POWER TRANSFORMER T1

AC POWER CORD

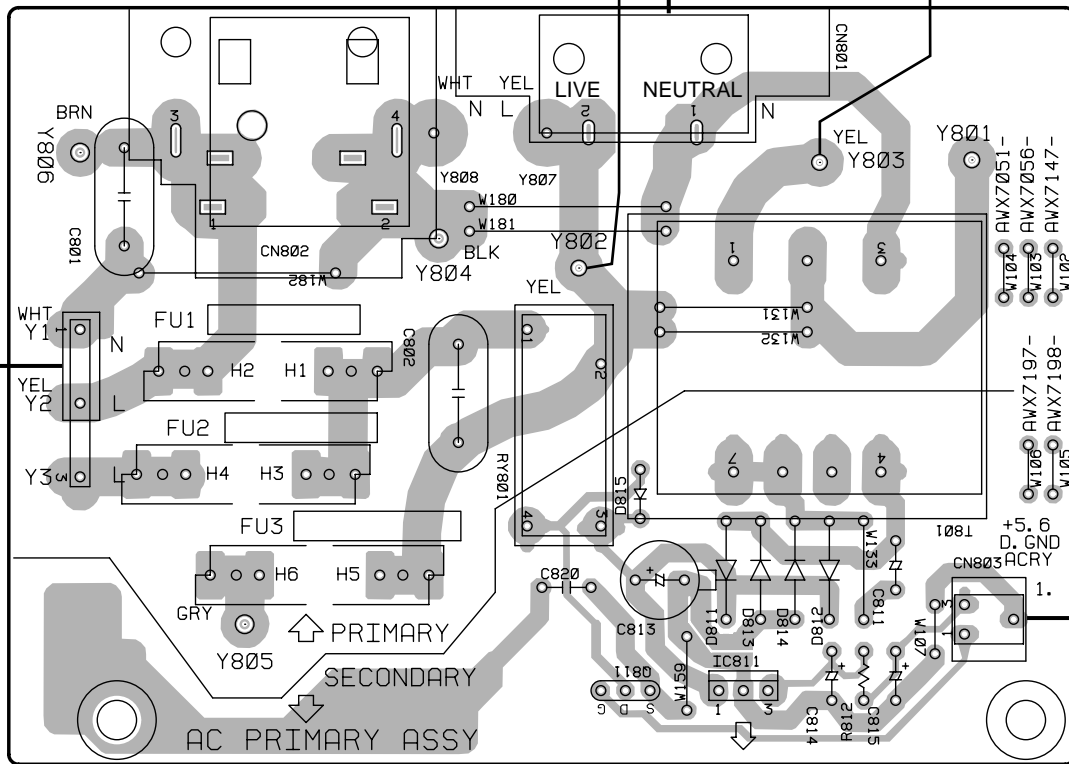

E AC PRIMARY ASSY

(ANP7228-A)

Q811 IC811

SIDE A

5. PCB PARTS LIST

- NOTES: ●Parts marked by "NSP" are generally unavailable because they are not in our Master Spare Parts List.
 ●The Δ mark found on some component parts indicates the importance of the safety factor of the part. Therefore, when replacing, be sure to use parts of identical designation.
 ●When ordering resistors, first convert resistance values into code form as shown in the following examples.
 Ex.1 When there are 2 effective digits (any digit apart from 0), such as 560 ohm and 47k ohm (tolerance is shown by J=5%, and K=10%).
 $560 \Omega \rightarrow 56 \times 10^1 \rightarrow 561 \dots\dots\dots RD1/4PU \boxed{5} \boxed{6} \boxed{1} J$
 $47k \Omega \rightarrow 47 \times 10^3 \rightarrow 473 \dots\dots\dots RD1/4PU \boxed{4} \boxed{7} \boxed{3} J$
 $0.5 \Omega \rightarrow R50 \dots\dots\dots RN2H \boxed{R} \boxed{5} \boxed{0} K$
 $1 \Omega \rightarrow 1R0 \dots\dots\dots RSIP \boxed{1} \boxed{R} \boxed{0} K$
 Ex.2 When there are 3 effective digits (such as in high precision metal film resistors).
 $5.62k \Omega \rightarrow 562 \times 10^1 \rightarrow 5621 \dots\dots\dots RN1/4PC \boxed{5} \boxed{6} \boxed{2} \boxed{1} F$

LIST OF WHOLE PCB ASSEMBLIES

Mark	Symbol and Description	Part No.			Remarks
		MY/EW Type	MY/GR Type	MV Type	
NSP	AF COMPLEX ASSY	AWK7422	AWK7422	AWK7422	
	└ AF ASSY	AWX7053	AWX7053	AWX7053	
	└ FRONT L ASSY	AWX7054	AWX7054	AWX7054	
	└ VOLUME ASSY	AWX7055	AWX7055	AWX7055	
NSP	CONTROL ASSY	AWG7009	AWG7009	AWG7010	
	└ FRONT R ASSY	AWX7050	AWX7050	AWX7050	
NSP	└ AC PRIMARY ASSY	AWX7051	AWX7051	AWX7056	
	└ HEADPHONE ASSY	AWX7052	AWX7052	AWX7052	
	└ POWER SW ASSY	AWX7057	AWX7057	AWX7057	

Mark	No.	Description	Part No.	Mark	No.	Description	Part No.
A		AF ASSY					
		SEMICONDUCTORS					
	IC151		M5220P		D307,D308		HZS9A1L
	IC451		NJM78M15FA		D456		MTZJ10C
	IC452		NJM79M05FA		D453		MTZJ36B
	IC251		TA8409S		D455		MTZJ4.7A
	IC101		TC9163AN		D457-D460		S5688G
	IC301		UPC4570C				
	Q327,Q328,Q409,Q410		2SA1048		COILS		
	Q321,Q322		2SA970		L201,L202,L401,L403,L405,L406		ATX1012
	Q311-Q314,Q329,Q330		2SA992		BEADS FILTER		
	Q309,Q310,Q315,Q316		2SC1845		L151-L154		LAU221J
	Q333,Q334		2SC1845		RELAYS		
	Q319,Q320		2SC2240		RY401-RY403		ASR7014
	Q317,Q318,Q331,Q332		2SC2458		RY101,RY102		RSR1026
	Q407,Q408		2SC2458		CAPACITORS		
	Q303,Q304		2SC2878		C461 (1 μ F/100V)		ACH1237
	Q451		2SC4793		C457,C458 (3.3 μ F/25V)		ACH7027
	Q102,Q104,Q153,Q403-Q406		2SK1132		C451 (10000 μ F/43V)		ACH7085
	Q414		2SK1132		C452 (10000 μ F/43V)		ACH7086
	Q401,Q402,Q413		DTA114ES		C101,C102,C105,C106		CCCSSL101J50
	Q101,Q103,Q151		DTA124ES		C109,C110,C113,C114		CCCSSL101J50
	Q152,Q251		DTC124ES		C153,C154		CCCSSL221J50
	Q411,Q412		DTC143ES		C303,C304		CCCSSL221K2H
Δ	Q323,Q324		IRF540		C313-C316		CCCSSL330K2H
Δ	Q325,Q326		IRF9540		C163,C164		CCCSSL390J50
Δ	D451		D5SBA20		C103,C104		CCCSSL470K2H
	D151,D201,D202,D301-D306		HSS104-02		C167,C168		CEANP1R0M50
	D309-D314		HSS104-02		C408		CEANP470M10
					C155,C156,C465		CEAS100M50
					C169,C170		CEAS101M25
					C459,C460		CEAS102M50
					C307,C308		CEAS221M25
					C467,C468		CEAS2R2M2A

A-407R

Mark	No.	Description	Part No.
	C251		CEAS470M25
	C157,C158		CEAS471M6R3
	C305,C306,C455,C456		CEBA100M50
	C463,C464		CEBA100M50
	C405-C407		CEBA2R2M50
	C301,C302		CEBA3R3M50
	C317,C318		CEBA470M50
	C325,C326		CEBAR47M50
	C319,C320		CEZA470M50
	C115,C116,C201,C321-C324		CFTYA224J50
	C161,C162,C470		CFTYA823J50
	C165,C166		CKCYB222K50
	C401-C404		CKCYB332K2H
	C117,C118,C171,C310,C327		CKCYF473Z50
	C409,C453,C454		CKCYF473Z50
	C172-C174		CKPUYB102K50
	C159,C160		CQMA243J50
RESISTORS			
△	R458,R459		RD1/4LMF2R2J
△	R133,R134,R171,R172		RD1/4MUF101J
△	R317,R318,R351-R354,R417		RD1/4MUF101J
△	R339-R346		RD1/4MUF221J
△	R331-R334		RD1/4MUF391J
△	R452		RD1/4MUF4R7J
△	R125,R126		RD1/4MUF821J
△	R367,R368		RD1/4PMF100J
△	R355,R356		RD1/4PMF222J
△	R461		RD1/4PMF470J
△	R361,R362		RD1/4PMF4R7J
△	R462		RD1/4PU100J
△	R460		RD1/4PU472J
△	R363,R364		RDR1/2PM152J
△	R315,R316		RDR1/4PM561J
△	R357-R360		RFA1/4PS101J
△	R349,R350		RN1/4PC2001F
△	R451		RS1LMF330J
△	R413-R416		RS1LMFR22J
△	R453		RS2LMF122J
△	R403,R404		RS2LMF331J
	VR301,VR302 (2.2kΩ)		VCP1123
	Other Resistors		RD1/4PU□□□J
OTHERS			
	CABLE HOLDER (3P)	51063-0305	
CN202	21P FFC CONNECTOR	9604S-21C	
	SCREW	ABA-298	
	SCREW	ABA1007	
	SCREW	ABA1052	
CN101,CN102	PIN JACK(8P)	AKB7023	
	SPEAKER TERMINAL 8-P	AKE1011	
	HEAT SINK M	ANH-697	
	HEAT SINK B	ANH1021	
J2	JUMPER WIRE	D15A03-075-2651	
CN204	4P PLUG	KM200IB4	
CN203	19P PLUG	KM200TA19	
CN401	CONNECTOR (3P)	KPE3	
JA401	REMOTE CONTROL JACK	RKN1004	
	PCB BINDER	VEF1040	
KN101,KN201,KN301,KN302,KN451	EARTH METAL FITTING	VNF1084	

Mark	No.	Description	Part No.
B FRONT L ASSY			
SEMICONDUCTORS			
	IC751		UPC4570C
	Q751,Q752		2SC1845
	Q702,Q703		2SC2458
	Q701,Q704-Q707		DTC124ES
	D702,D711		HSS104-02
	D701,D704-D706		SLR-342VCT31
SWITCHES			
	S701-S704		ASG1034
CAPACITORS			
	C701 (3.3μF/25V)		ACH7027
	C753,C754		CCCSL151J50
	C751,C752,C755,C756		CEAS100M50
	C759,C760		CEASR47M50
	C761,C762		CEJAR10M50
	C757,C758		CFTLA153J50
	C765		CKCYF473Z50
	C763,C764		CKPUYB102K50
	C711		CKPUYF473Z16
RESISTORS			
	R771,R772		RD1/4MUF101J
	VR751,VR752 (30kΩ)		ACS7016
	Other Resistors		RD1/4PU□□□J
OTHERS			
	CABLE HOLDER (7P)	51063-0705	
J3	JUMPER WIRE	D15A07-200-2651	
CN701	CONNECTOR (15P)	KPE15	
	REMOTE RECEIVER UNIT	GP1U28X	
C VOLUME ASSY			
SEMICONDUCTORS			
	Q501-Q510		2SK246
	Q512		DTA124ES
	Q511,Q513,Q514		DTC124ES
	D501-D510,D512,D513		HSS104-02
CAPACITORS			
	C501,C502		CCCSL471J50
	C512		CEBA470M10
	C503,C504		CFTYA823J50
	C511		CKCYF473Z50
RESISTORS			
	VR501 (50kΩ)		ACX1090
	Other Resistors		RD1/4PU□□□J
OTHERS			
	CN501 19P SOCKET	KP200TA19L	
	CN502 CONNECTOR (7P)	KPE7	

Mark	No.	Description	Part No.
D FRONT R ASSY			
SEMICONDUCTORS			
	IC601		PD5369A
	IC603		TC74HC00AP
	IC602		TC74HC107AP
	Q609		2SA1048
	Q607,Q610,Q618		2SC2458
	Q612,Q613,Q615,Q616		DTA124ES
	Q601-Q606,Q608,Q614,Q617		DTC124ES
	D608-D610,D615,D618-D622		HSS104-02
	D636		HSS104-02
	D631		MTZJ2.2B
	D617		MTZJ4.3A
	D607		SLR-342DCT31
	D601-D606,D632-D635		SLR-342VCT31

COILS

L601-L608	LAU221J
-----------	---------

SWITCHES

S603,S604,S606	ASG1034
S601	ASX7002

CAPACITORS

C601,C625,C635 (3.3μF/25V)	ACH7027
C605 (0.22F)	ACH7058
C624	CEJA1R0M50
C610,C637	CEJA2R2M50
C603	CEJA470M16
C604	CKCYF103Z50
C609,C613-C623,C626,C627	CKPUYF103Z25
C632-C634	CKPUYF103Z25
C628,C629,C631	CKPUYF473Z16

RESISTORS

VR601 (500KΩ)	ACS7014
Other Resistors	RD1/4PU□□□J

OTHERS

X601 CERAMIC RESONATOR (4.19MHz)	VSS1014
CABLE HOLDER (15P)	51063-1505
CN601 21P FFC CONNECTOR	9604S-21F
J4 JUMPER WIRE	D15A15-125-2651

E AC PRIMARY ASSY

(1) CONTRAST TABLE

AWX7051 and AWX7056 are constructed the same except for the following :

Mark	Symbol and Description	Part No.		Remarks
		AWX7051	AWX7056	
△	CN802 AC SOCKET 1P	AKP1034	Not used	

(2) PARTS LIST FOR AWX7051

SEMICONDUCTORS

IC811	NJM78M56FA
Q811	2SK1132
D815	HSS104-02
D811-D814	S5688G

TRANSFORMER

△ T801	ATT7009
--------	---------

RELAY

△ RY801	RSR1037
---------	---------

Mark	No.	Description	Part No.
CAPACITORS			
△	C801,C802 (0.01μF/AC250V)		ACG7020
	C815 (3.3μF/25V)		ACH7027
	C813		CEAT471M25
	C814		CEBA470M10
	C811		CEYANP1R0M50

RESISTORS

All Resistors	RD1/4PU□□□J
---------------	-------------

OTHERS

△ Y802,Y803 BOARDIN READ WIRE	ADX7207
△ CN802 AC SOCKET 1P	AKP1034
△ CN801 AC INLET	AKP7005
CN803 CONNECTOR (3P)	KPE3
H1,H2 FUSE HOLDER	RKR1003

F HEADPHONE ASSY

CAPACITORS

C551,C552	CKCYB392K50
-----------	-------------

OTHERS

CABLE HOLDER (3P)	51063-0305
J5 JUMPER WIRE	D15A03-150-2651
JA501 HEADPHONE JACK	RKN1002

G POWER SW ASSY

SWITCH

△ S901	ASG1035
--------	---------

CAPACITOR

△ C901 (0.0033μF/AC250V)	ACG7017
--------------------------	---------

6. ADJUSTMENTS

6.1 IDLE CURRENT ADJUSTMENT

- CAUTION : Heatsinks' (Q323–Q326) DC level is equal to +B or -B.
Don't touch them or you will be electricary chocked.

1. Connect the measuring instrument as Fig.6-1. (R415 or R416)
2. Set the VOLUME CONTROL to minimum, BASS TONE CONTROL to center, TREBLE TONE CONTROL to center and BALANCE CONTROL to center. Set VR301 and VR302 to minimum.
3. Set the POWER switch to ON.
4. Adjust VR301 (VR302) so that the voltage between both sides of R415 (R416) becomes $16\text{mV} \pm 1\text{mV}$. (Within 10 seconds from when the relay is turned ON)
5. Ages for 7 minutes.
6. Adjust VR301 (VR302) so that the voltage between both sides of R415 (R416) becomes $11\text{mV} \pm 1\text{mV}$.

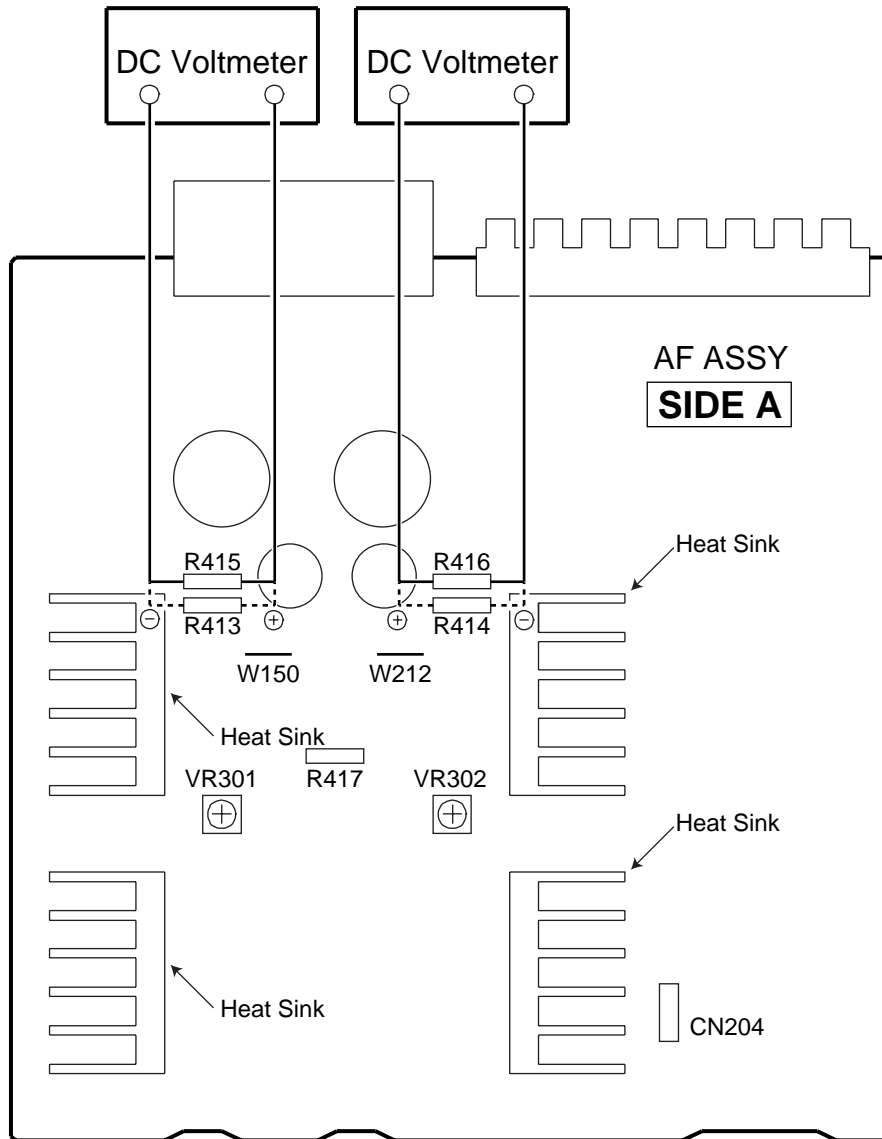

Fig.6-1 Adjustment Method

7. GENERAL INFORMATION

7.1 IC INFORMATION

■ PD5369A (FRONT R ASSY : IC601)

• REMOTE CONTROL AMP MICROCOMPUTER

- The information shown in the list is basic information and may not correspond exactly to that shown in the schematic diagrams.

• Pin Assignment (Top view)

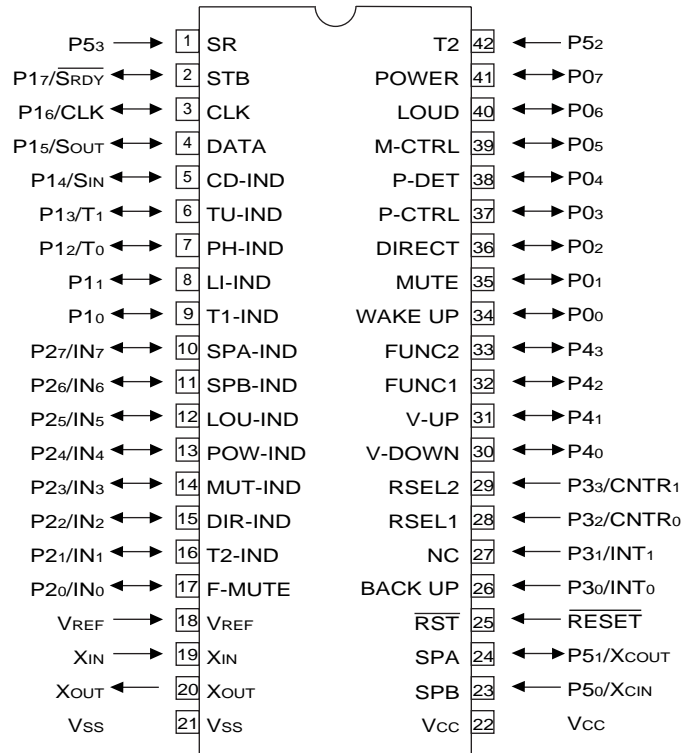

• Pin Function

No.	Pin name	I/O	Function
1	P5 ₃	I	Remote control signal input pin.
2	P1 ₇ /S _{RDY}	O	STB for TC9163N.
3	P1 ₆ /CLK	O	CLOCK for TC9163N.
4	P1 ₅ /S _{OUT}	O	DATA for TC9163N.
5	P1 ₄ /S _{IN}	O	CD INDICATOR.
6	P1 ₃ /T ₁	O	TUNER INDICATOR.
7	P1 ₂ /T ₀	O	PHONO INDICATOR.
8	P1 ₁	O	LINE INDICATOR.
9	P1 ₀	O	TAPE1 INDICATOR.
10	P2 ₇ /IN ₇	O	SPEAKER-A INDICATOR.
11	P2 ₆ /IN ₆	O	SPEAKER-B INDICATOR.
12	P2 ₅ /IN ₅	O	LOUDNESS INDICATOR.
13	P2 ₄ /IN ₄	O	POWER (STAND-BY) INDICATOR.
14	P2 ₃ /IN ₃	O	MUTE INDICATOR. MUTE ON : Repeats H and L every 1 second. Normal : "H"
15	P2 ₂ /IN ₂	O	DIRECT INDICATOR.
16	P2 ₁ /IN ₁	O	TAPE2 INDICATOR.
17	P2 ₀ /IN ₀	O	FUNCTION switch MUTE.
18	V _{REF}	I	Pulls up to 5V.
19	X _{IN}	I	4.19MHz .
20	X _{OUT}	O	Ceramic vibrating and connecting terminal.
21	V _{SS}	-	Digital GND.
22	V _{CC}	-	Power supply +5V.
23	P5 ₀ /X _{CIN}	I	SPEAKER-B KEY input.

No.	Pin name	I/O	Function
24	P5 ₁ /X _{COUT}	I	SPEAKER-A KEY input.
25	RESET	I	Reset pin.
26	P3 ₀ /INT ₀	I	BACK UP detection pin. interrupt specification.
27	P3 ₁ /INT ₁	O	Not used.
28	P3 ₂ /CNTR ₀	I	REC selector input 1.
29	P3 ₃ /CNTR ₁	I	REC selector input 2. interrupt specification.
30	P4 ₀	O	Volume DOWN data output.
31	P4 ₁	O	Volume UP data output.
32	P4 ₂	I	FUNCTION selector input 1.
33	P4 ₃	I	FUNCTION selector input 2.
34	P0 ₀	I	WAKE UP input. Key on wake up specification.
35	P0 ₁	I	MUTE KEY input. Key on wake up specification.
36	P0 ₂	I	DIRECT KEY input. Key on wake up specification.
37	P0 ₃	O	Protection control pin.
38	P0 ₄	I	Output error detection pin
39	P0 ₅	O	MUTING control pin.
40	P0 ₆	I	LOUDNESS KEY input. Key on wake up specification.
41	P0 ₇	I	POWER KEY input. Key on wake up specification.
42	P5 ₂	I	TAPE2 KEY input.

7.2 BLOCK DIAGRAM

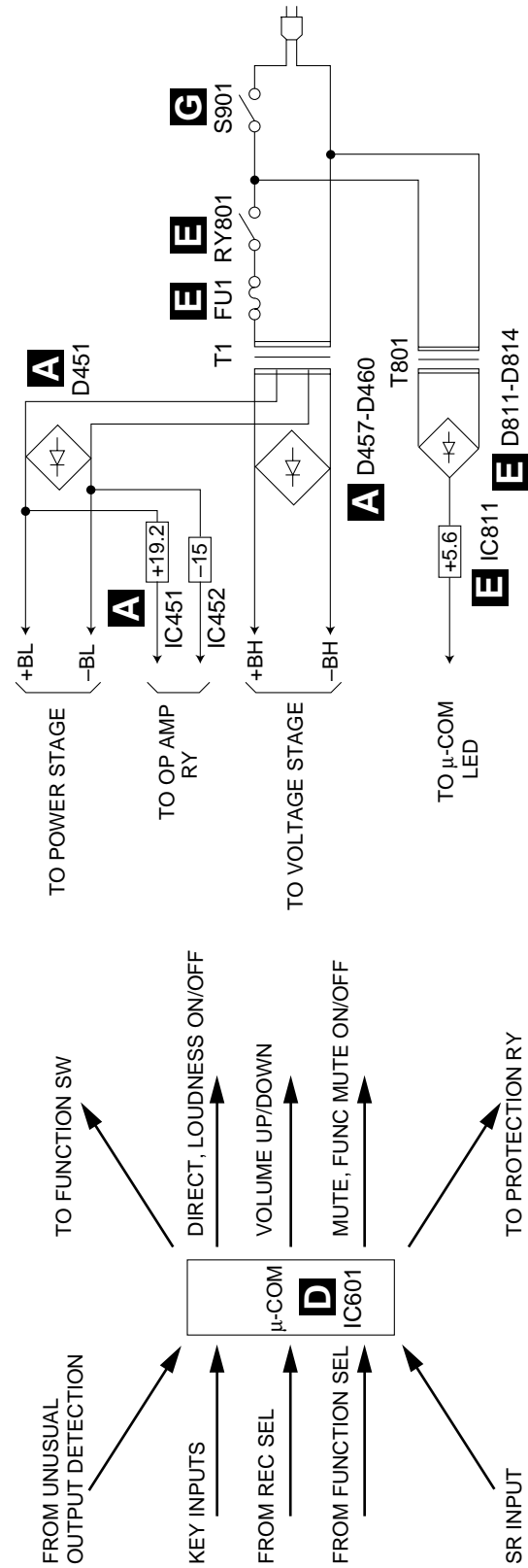
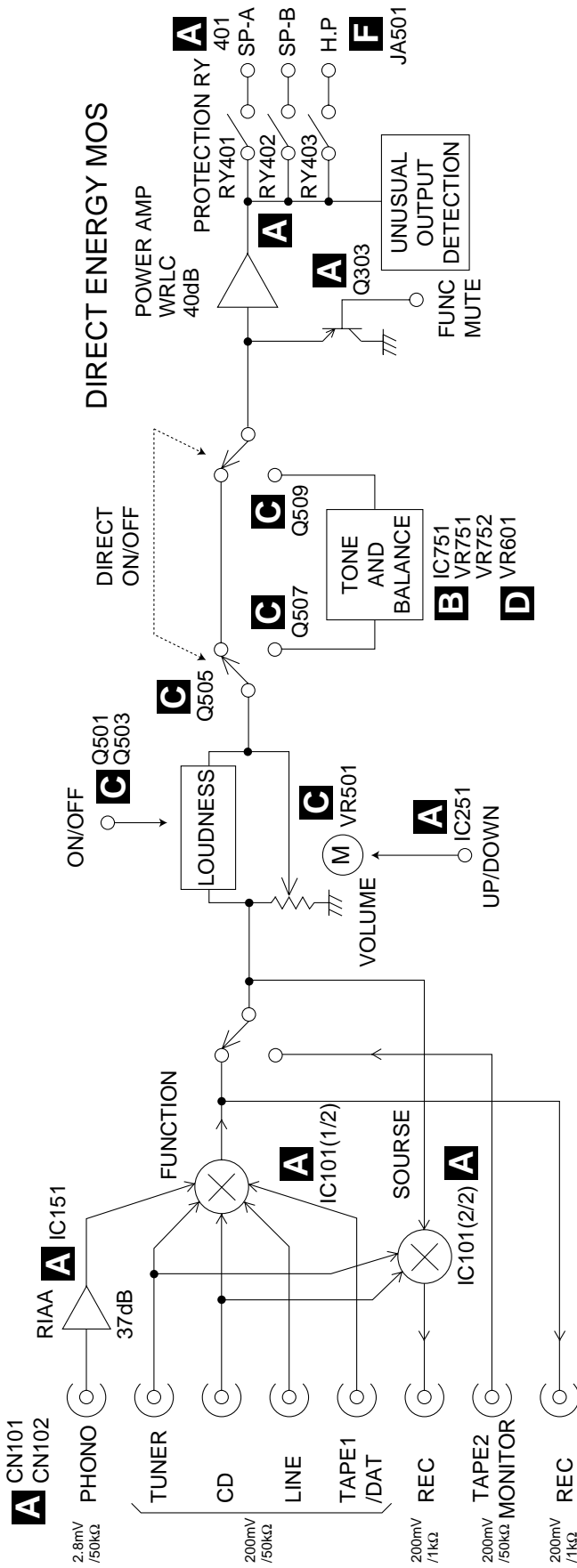

8. PANEL FACILITIES AND SPECIFICATIONS

8.1 REAR PANEL

Illustration shows U.K. model

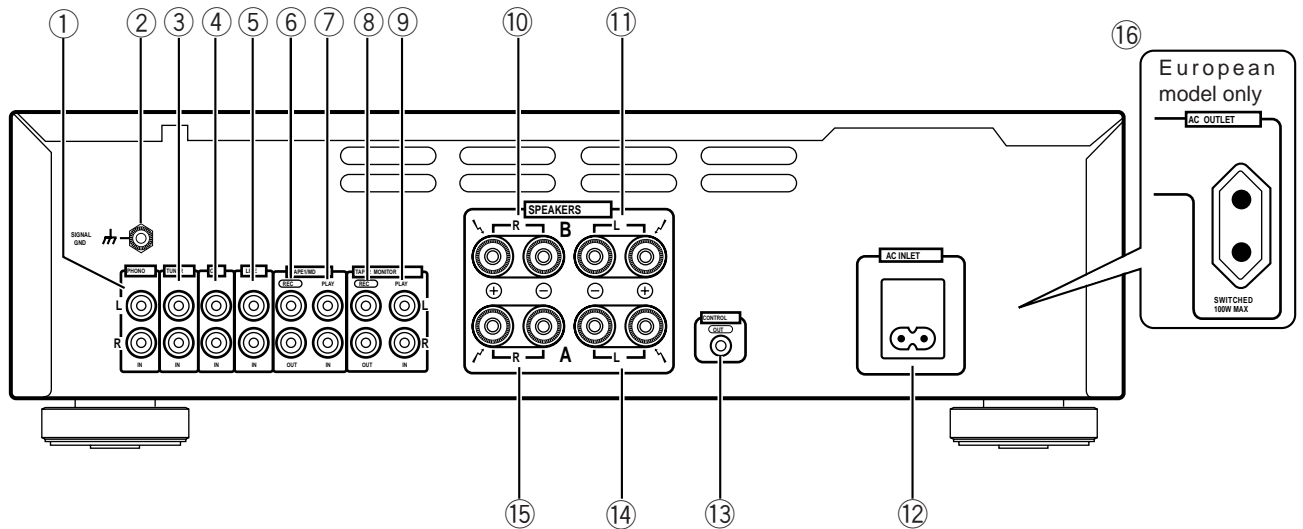

- | | |
|---|---|
| <p>① PHONO terminals</p> <p>② SIGNAL GND (Turntable ground) terminal</p> <p>③ TUNER terminals</p> <p>④ CD terminals</p> <p>⑤ LINE terminals</p> <p>⑥ TAPE 1/MD REC (OUT) terminals</p> <p>⑦ TAPE 1/MD PLAY (IN) terminals</p> <p>⑧ TAPE 2 MONITOR REC (OUT) terminals</p> <p>⑨ TAPE 2 MONITOR PLAY (IN) terminals</p> | <p>⑩ SPEAKERS B terminals (Right channel)</p> <p>⑪ SPEAKERS B terminals (Left channel)</p> <p>⑫ AC INLET jack
Connect one end of the power cord to here and the other end to an AC wall socket, or the AC outlet of an audio timer. If you are going to be away from home for a long period of time, disconnect the unit from the wall socket.</p> <p>⑬ CONTROL OUT jack
This jack is for outputting control signals when operating other components bearing the  mark with the amplifier's remote control unit.</p> <p>⑭ SPEAKERS A terminals (Left channel)</p> <p>⑮ SPEAKERS A terminals (Right channel)</p> <p>⑯ AC OUTLET (European model only)</p> |
|---|---|

8.2 FRONT PANEL

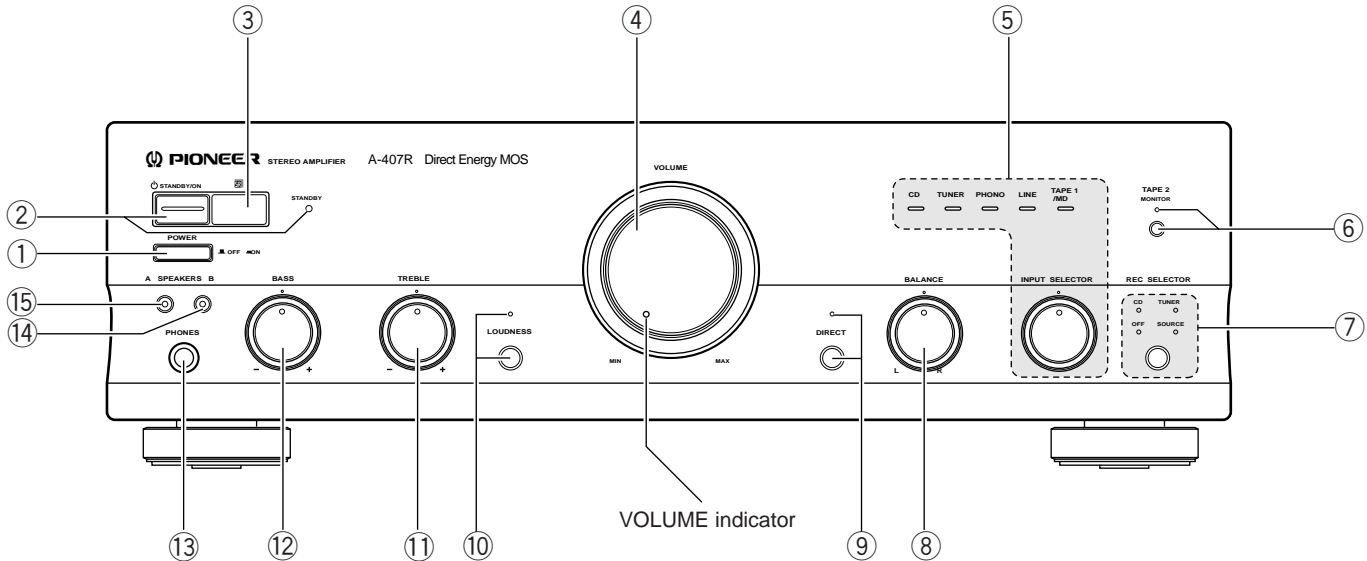

① **POWER (■ OFF/ ■ ON) switch**

Press to turn power to the unit ON and OFF.

② **STANDBY/ON switch/indicator**

This is the switch for electric power.

This switch does not function unless the POWER ■ OFF/ ■ ON switch is set to ON.

ON : When set to the ON position, power is supplied and the unit becomes operational.

STANDBY : When set to the STANDBY position, the main power flow is cut and the unit is no longer fully operational. A minute flow of power feeds the unit to maintain operation readiness.

When the STANDBY indicator lights, the unit is in STANDBY.

NOTE:

When performing timer recording with this unit, be sure to set the POWER STANDBY/ON switch to ON.

③ **Remote control sensor window**

④ **VOLUME control**

Use to adjust the volume level.

NOTE:

The TONE effect functions regardless of volume levels.

⑤ **INPUT SELECTOR knob/indicators**

Turn the knob clockwise or counterclockwise so that the indicator lights for your desired input source. Turning the knob clockwise causes the lit indicator to right. Turning counterclockwise causes it to left.

CD : For compact disc playback with a CD player.

TUNER : For AM or FM broadcast reception with a tuner.

PHONO : For record playback with a turntable.

LINE : Set to this position when listening to a program from a component connected to the LINE terminals.

TAPE 1/MD : For playback with a cassette deck or MD recorder connected to the TAPE 1/MD terminals.

⑥ **TAPE 2 MONITOR button/indicator**

Use when there is an adaptor component (graphic equalizer, etc.) or cassette deck connected to the TAPE 2 MONITOR terminals.

Off : Indicator goes out when not in use.

On : Indicator lights when using the adaptor component or listening to the cassette deck.

NOTE:

When no connections are made to the TAPE 2 MONITOR terminals, or when they are not in use, be sure to set this switch to the off position. (No sound will be heard if it is set to the on position.)

⑦ REC SELECTOR switch /indicator(For TAPE 1/MD terminals)

This switch is used to select the recording source component. The signal from the selected component is output at the TAPE1/MD jacks for recording. To select a recording source component, press the REC SELECTOR switch so that the indicator of the desired source component lights up. When this switch is set to [TUNER] or [CD], the signal from the selected component can be recorded regardless of the input selector switch and TAPE2 MONITOR button settings.

- CD** : To record from the equipment connected to the CD terminals.
- TUNER** : To record from the equipment connected to the TUNER terminals.
- SOURCE** : To record from the equipment selected by the INPUT SELECTOR knob.
- OFF** : In this position, nothing from the REC terminals of TAPE 1/MD is output. Set to this position when not recording; the cassette deck will be disconnected, improving sound quality.

NOTE:

The function selected using the INPUT SELECTOR knob will be recorded irrespective of the position of the REC SELECTOR switch (TAPE 2 MONITOR terminals).

⑧ BALANCE control

Should normally be left in the center position. Adjust the balance if the sound is louder from one of the speakers. If the right side is louder, turn toward the L (left) position and if the left side is louder, turn toward the R (right) position.

NOTE:

This control does not operate when the DIRECT button is in the on position.

⑨ DIRECT button/indicator

Use this button when you do not wish to pass the output from input terminal equipment through the various frequency adjusting circuits (BASS, TREBLE, BALANCE, LOUDNESS).

- On** : The indicator lights. The signals input through the input terminals are reproduced without passing through the various frequency adjusting circuits. This results in flat, pure sound which is a more faithful reproduction of the input source.
- Off** : The indicator goes out. The signal passes through the various frequency adjusting circuits.

⑩ LOUDNESS button/indicator

Use when listening at low volume level.

- On** : The indicator lights. Boosts low and high frequencies to give added punch to playback even at low volume level.
- Off** : The indicator goes out. Should normally be left in this position.

NOTE:

This button does not operate when the DIRECT button is in the on position.

⑪ TREBLE tone control

Use to adjust the high-frequency tone. The center position is the flat (normal) position. When turned to the right, the high-frequency tone is emphasized; when turned to the left, the high-frequency tone is de-emphasized.

NOTE:

This control does not operate when the DIRECT button is in the on position.

⑫ BASS tone control

Use to adjust the low-frequency tone. The center position is the flat (normal) position. When turned to the right, the low-frequency tone is emphasized; when turned to the left, the low-frequency tone is de-emphasized.

NOTE:

This control does not operate when the DIRECT button is in the on position.

⑬ PHONES jack

When using headphones, insert the plug into this jack.

⑭ SPEAKERS B (ON/OFF) button/indicator

Use this button to listen to the speaker system connected to the SPEAKERS B terminals.

- On** : The indicator lights. Sound is heard from the speaker system.
- Off** : The indicator goes out. No sound is heard from the speaker system. Set to this position when listening with headphones.

⑮ SPEAKERS A (ON/OFF) button/indicator

Use this button to listen to the speaker system connected to the SPEAKERS A terminals.

- On** : The indicator lights. Sound is heard from the speaker system.
- Off** : The indicator goes out. No sound is heard from the speaker system. Set to this position when listening with headphones.

8.3 REMOTE CONTROL

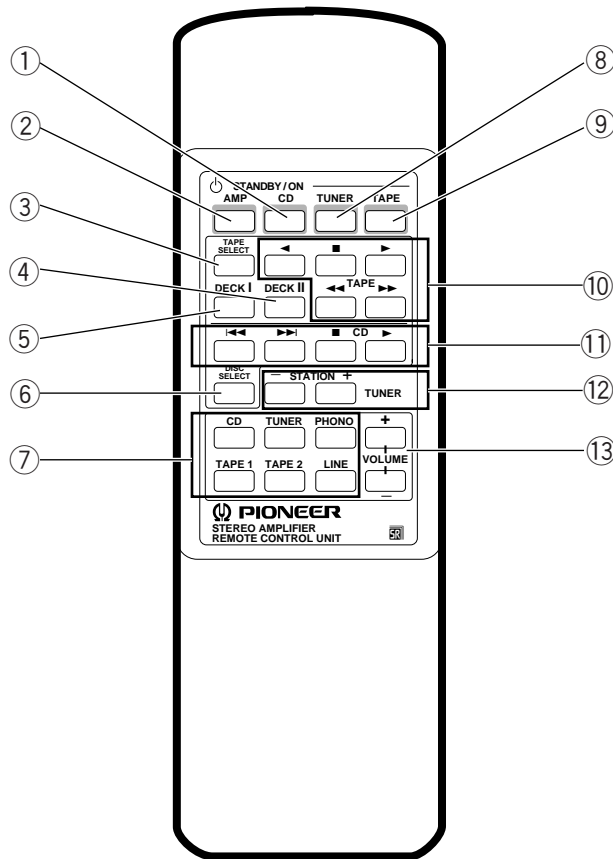

- ① **CD POWER button**
Switches CD player power STANDBY/ON.
- ② **AMP POWER button**
Switches the amplifier power STANDBY/ON.
- ③ **TAPE SELECT button**
Selects the cassette No. (1 to 6) for a multi-cassette changer.
- ④ **DECK II button**
To operate Deck II, press this button before pressing the operating buttons. Also, when using a single deck, press this button before pressing the operating buttons.
- ⑤ **DECK I button**
To operate Deck I, press this button before pressing the operating buttons.
- ⑥ **DISC SELECT button**
Press this to select discs on a multi or twin tray compact disc player.
- ⑦ **Input selector buttons**
Use to select the playback source.
CD : For compact disc playback with a CD player.
TUNER : For AM or FM broadcast reception with a tuner.
PHONO : For record playback with a turntable.
TAPE 1 : For playback with a cassette deck or MD recorder connected to the TAPE 1/MD terminals.
TAPE 2 : For playback with a cassette deck or adaptor connected to the TAPE 2 MONITOR terminals.
LINE : For playback with a component connected to the LINE terminal.

- ⑧ **TUNER POWER button**
Switches TUNER power STANDBY/ON.
- ⑨ **TAPE POWER button**
Switches the cassette deck power STANDBY/ON.
- ⑩ **TAPE operation buttons**
 - ◀, ▶ : Playback in the direction of the arrows.
 - : Stop
 - ◀◀, ▶▶ : Tape fast forward/reverse.
- ⑪ **CD player operation buttons**
 - ◀◀ : Returns you to the start of the current track (Track search).
 - ▶▶ : Takes you to the start of the next track (Track search).
 - : Stop
 - ▶ : Play
- ⑫ **STATION +, - buttons (TUNER)**
Calls each station number in sequence.
- ⑬ **VOLUME +, - buttons**
 - + Increases the volume.
 - Decreases the volume.

NOTE:
When the accessory remote control unit is used to operate other PIONEER components with the  mark, it cannot be used to operate functions which do not correspond to the functions listed on the remote control unit.

8.4 SPECIFICATIONS

Amplifier Section

Continuous power output
(both channels driven at 20 Hz to 20 kHz)**

T.H.D. 0.06 %, 8 Ω	45 W + 45 W*
T.H.D. 0.09 %, 4 Ω	65 W + 65 W*

DIN Continuous power output (both channels driven at 1 kHz)

T.H.D. 1.0 %, 8 Ω	60 W + 60 W
T.H.D. 1.0 %, 4 Ω	90 W + 90 W

Total harmonic distortion**

20 Hz to 20 kHz, 20 W, 8 Ω	0.06 %*
----------------------------	---------

• **Power output specification is for when power supply is 230V.**

Input sensitivity/ impedance

PHONO (MM)	2.8 mV/ 50 kΩ
CD, TUNER, LINE, TAPE 1/MD,	
TAPE 2 MONITOR	200 mV/ 50 kΩ

PHONO (MM) overload level

1 kHz, T.H.D. 0.1 %	150 mV
---------------------	--------

Output level/ impedance

TAPE 1/MD, TAPE 2 MONITOR output	200 mV/ 1 kΩ
----------------------------------	--------------

Frequency response

PHONO (MM)	20 Hz to 20 kHz ± 0.5 dB
CD, TUNER, LINE, TAPE 1/MD,	
TAPE 2 MONITOR	5 Hz to 100 kHz \pm_{-3}^{+0} dB*

Tone control

BASS	± 8 dB (100 Hz)
TREBLE	± 8 dB (10 kHz)

Loudness contour (volume control set at - 30 dB position)

	+ 5 dB (100 Hz)/ + 3 dB (10 kHz)
--	----------------------------------

Signal-to-Noise ratio (IHF short circuit, A network)

PHONO (MM, 5 mV input)	86 dB*
CD, TUNER, LINE, TAPE 1/MD,	
TAPE 2 MONITOR	106 dB*

Signal-to-Noise ratio (DIN, continuous power/ 50 mW)

PHONO (MM)	71 dB/ 67 dB*
CD, TUNER, LINE, TAPE 1/MD,	
TAPE 2 MONITOR	95 dB/ 71 dB*

Power Supply/ Miscellaneous

Power requirements AC 220 - 230 Volts, 50/ 60 Hz

Power consumption 160 W

AC outlet(European model only)

Switched(x1)	100W
--------------	------

Dimensions (including knobs and other protruding parts)

	420 (W) × 335 (D) × 128 (H) mm
--	--------------------------------

Weight (without package)

	6.9 kg
--	--------

Accessories

Remote control unit	1
Batteries (AA/R6P)	2
Operating instructions	1
Power cord(Rated current 2.5 A)	1

NOTE:

Specifications and design subject to possible modification without notice, due to improvements.

* Measured with the DIRECT button set to on.

** Measured by Audio Spectrum Analyzer.

• ACCESSORIES

