

STR-V220

SERVICE MANUAL

US Model



This receiver incorporates the Dolby* Pro Logic Surround system.

* Manufactured under license from Dolby Laboratories Licensing Corporation. DOLBY, the double-D symbol  and "PRO LOGIC" are trademarks of Dolby Laboratories Licensing Corporation.

POWER OUTPUT AND TOTAL HARMONIC DISTORTION

With 8 ohm loads, both channels driven, from 20 - 20,000 Hz; rated 60 watts per channel minimum RMS power, with no more than 0.3% total harmonic distortion from 250 milliwatts to rated output.

Amplifier section

POWER OUTPUT

Stereo mode (8 ohms 20 Hz - 20 kHz, THD 0.3%)
60 W + 60 W

Surround mode (8 ohms at 1 kHz, THD 0.08%)

Front: 60 W/ch
Center*: 60 W
Rear*: 60 W/ch

* Depending on the surround mode and the source, sound will not be output.

SPECIFICATIONS

Frequency response

CD, TAPE/MD, TV/SAT,
VIDEO:
10 Hz - 50 kHz ± 1 dB

Inputs

	Sensitivity	Impedance	S/N (weighting network, input level)
CD	200 mV		82 dB
TAPE/MD, TV/SAT, VIDEO	150 mV	50 kilohms	(A, 150 mV)

Outputs

TAPE/MD REC OUT:
Voltage: 150 mV,
Impedance: 10 kilohms
VIDEO AUDIO OUT:
Voltage: 150 mV,
Impedance: 10 kilohms
MIX AUDIO OUT:
Voltage: 2 V
Impedance: 10 kilohms

PHONES:

Accepts low and high impedance headphones

MUTING

Full mute

BASS BOOST

+10 dB at 70 Hz

TONE

± 8 dB at 100 Hz and 10 kHz

FM tuner section

Tuning range 87.5 - 108.0 MHz

Antenna terminals

300 ohms, balanced
75 ohms, unbalanced

Sensitivity

Mono: 18.3 dBf, 4.5 μ V
Stereo: 38.3 dBf, 45 μ V

Usable sensitivity

11.2 dBf, 2 μ V (IHF)

S/N

Mono: 76 dB
Stereo: 70 dB

— Continued on next page —

FM STEREO/FM-AM RECEIVER



SONY®

4-2. SCHEMATIC DIAGRAM – MAIN (1/3) SECTION –

- See page 6 for Waveforms.
- See page 13 for Printed Wiring Board.
- See page 23 for IC Block Diagrams.

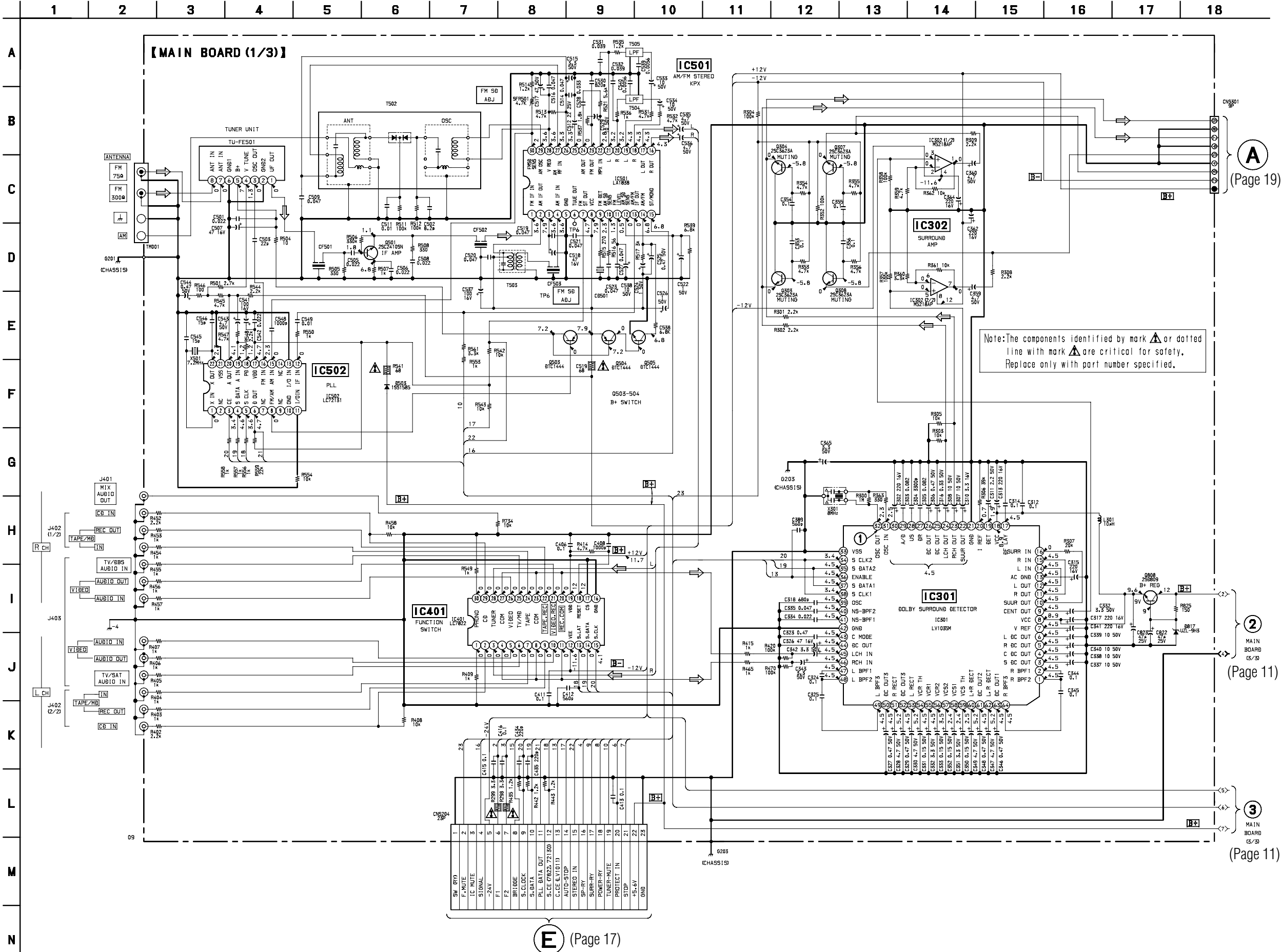

(Page 19)

(Page 11)

(Page 11)

4-3. SCHEMATIC DIAGRAM – MAIN (2/3) SECTION –
 • See page 13 for Printed Wiring Board.

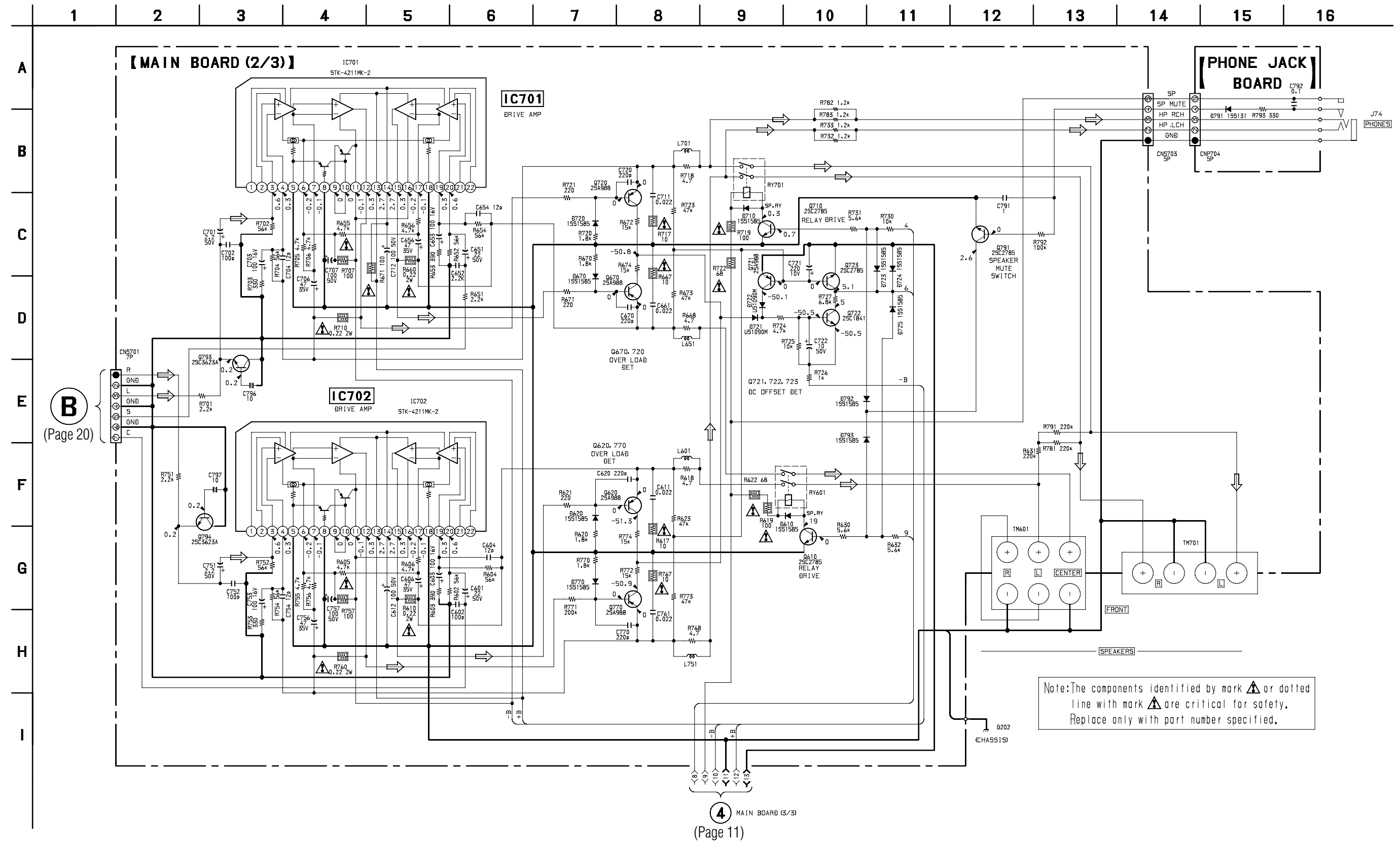

4-4. SCHEMATIC DIAGRAM – MAIN (3/3) SECTION –
• See page 24 for IC Block Diagrams.

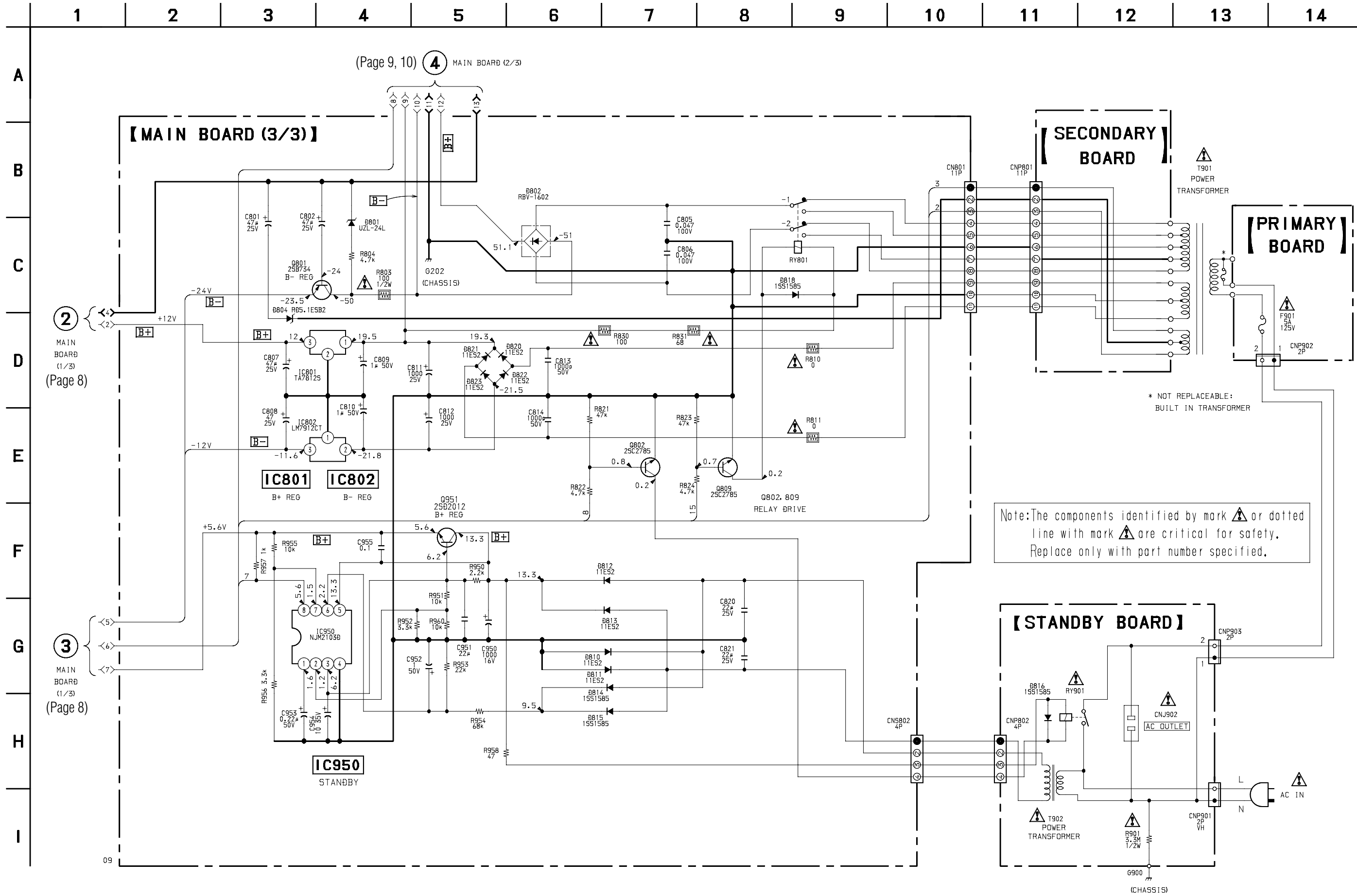

Note: The components identified by mark or dotted line with mark are critical for safety. Replace only with part number specified.

4-7. SCHEMATIC DIAGRAM - DISPLAY SECTION -

- See page 6 for Waveforms.
- See page 25 for IC Block Diagrams.
- See page 26 for IC Pin Function.

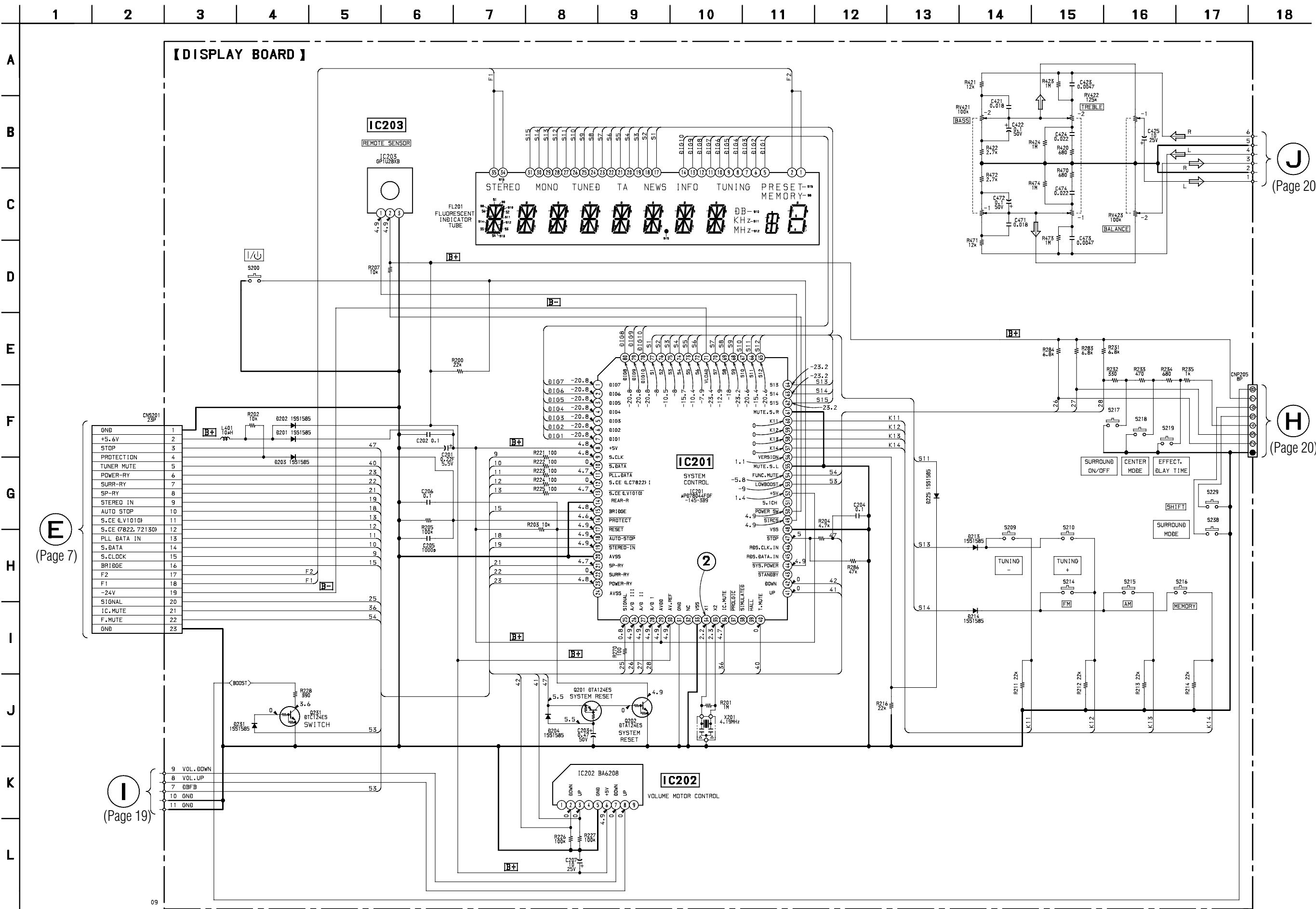

4-8. SCHEMATIC DIAGRAM – PANEL SECTION –

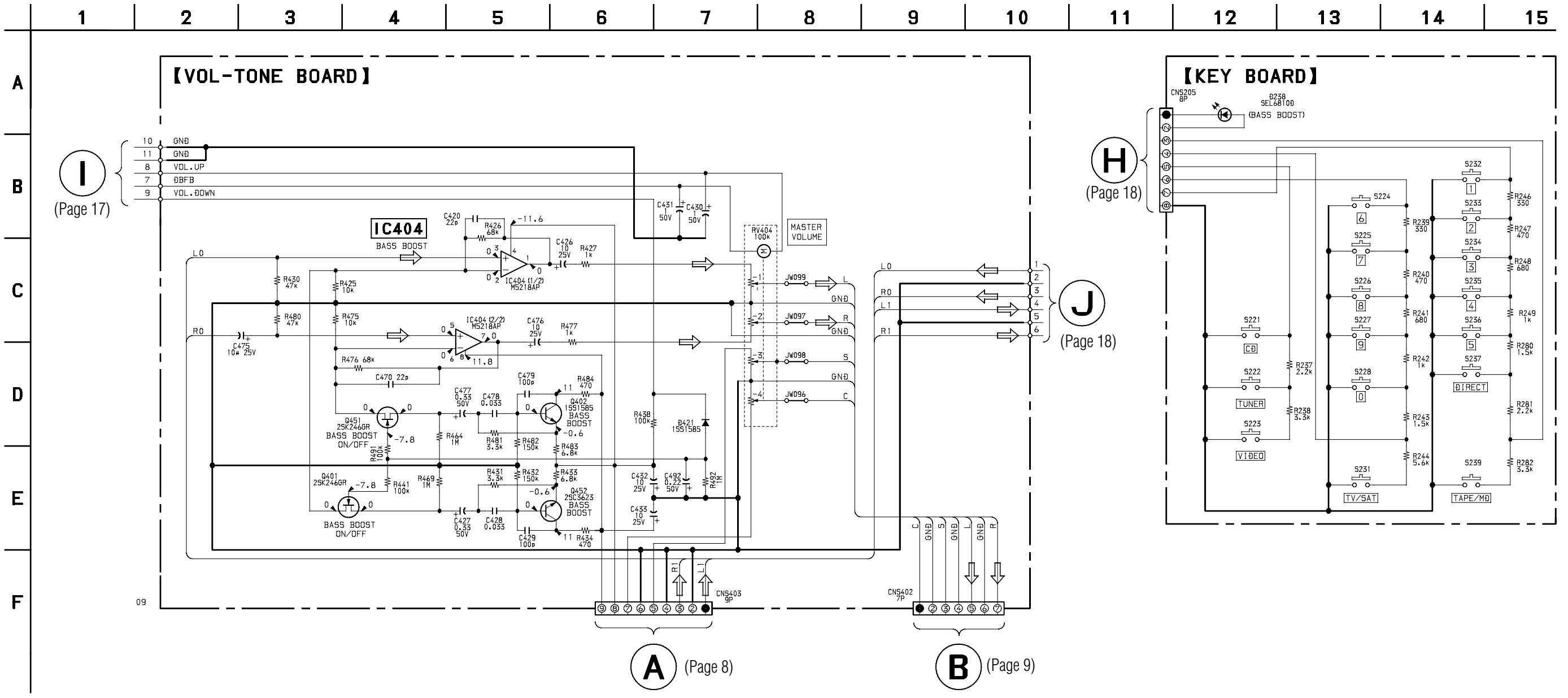

4-10. IC BLOCK DIAGRAMS

• Main section

IC301 LV1035M

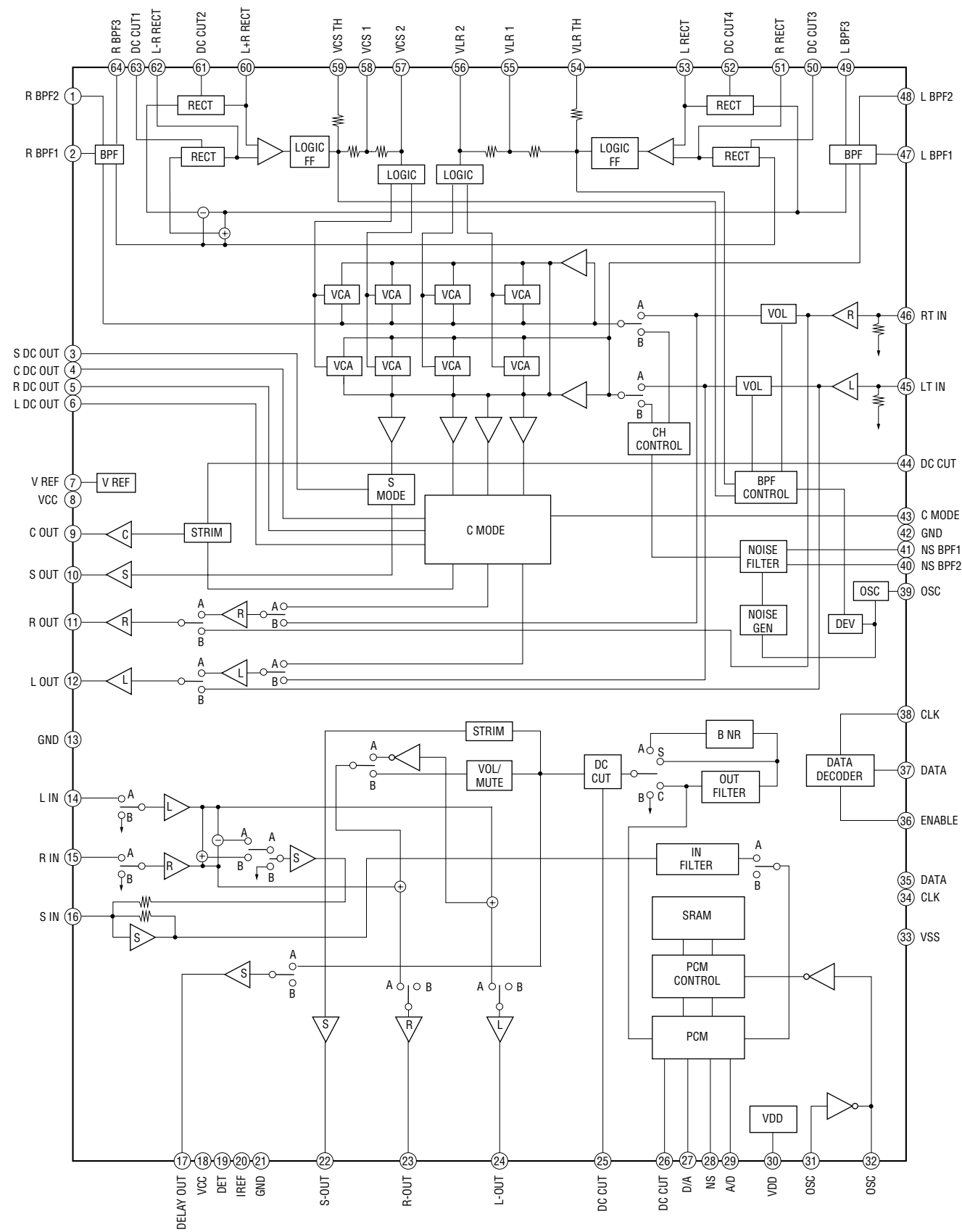

IC401 LC7822

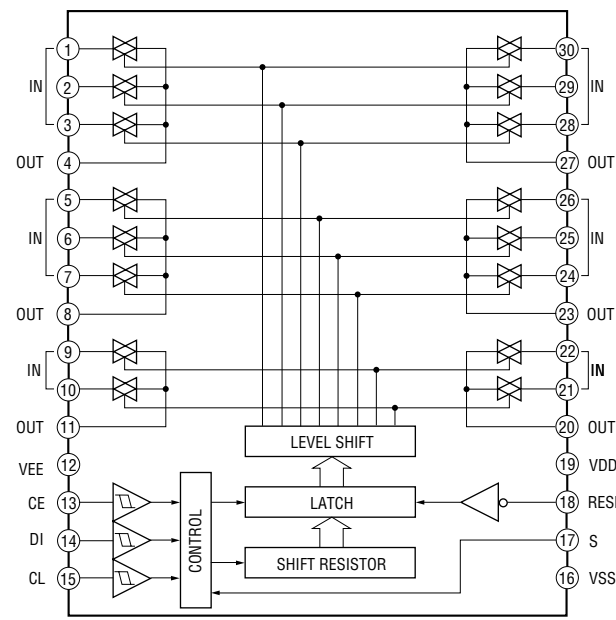

IC950 NJM2103D

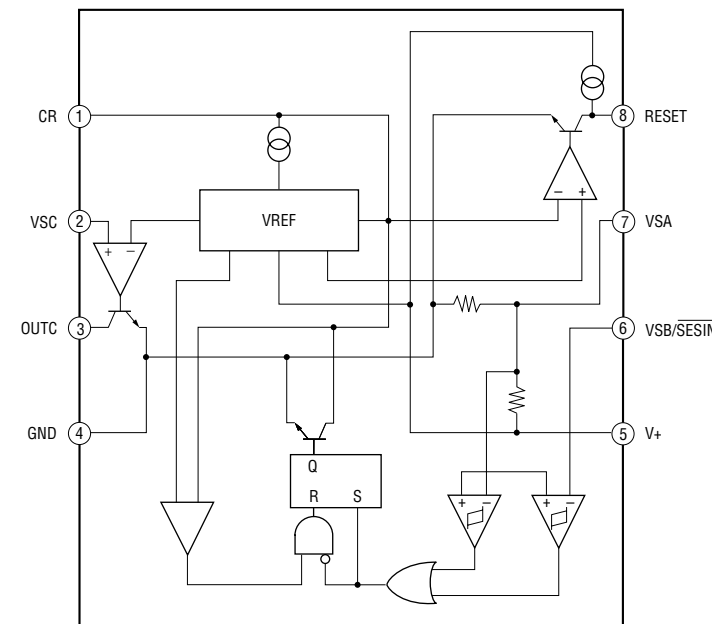

IC501 LA1838

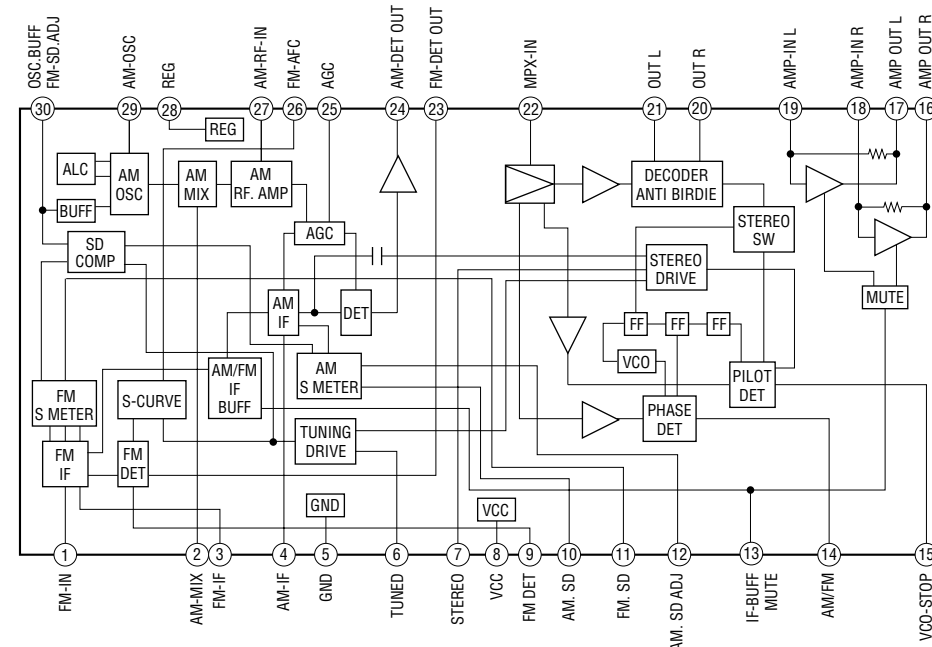

IC502 LC72131

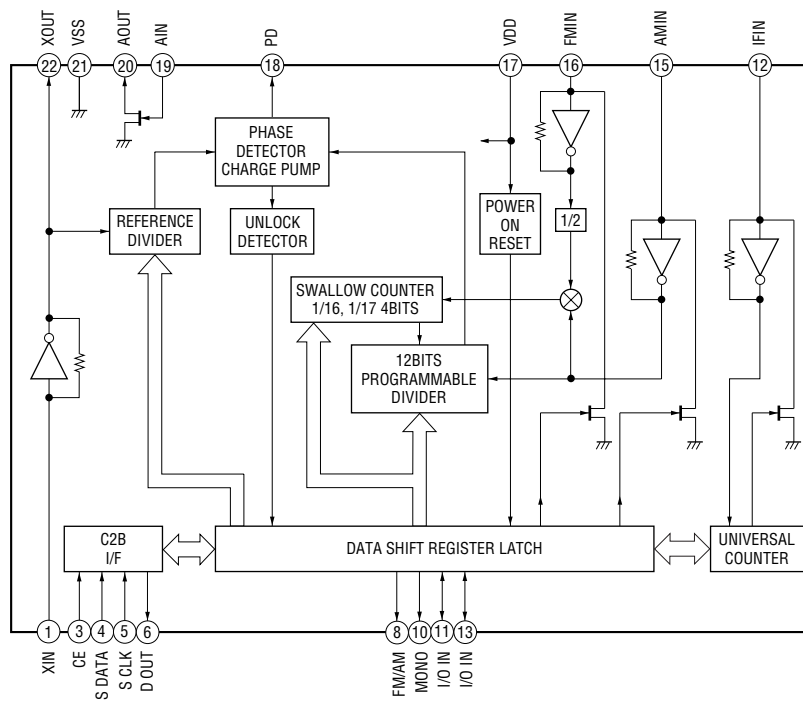

• **Display section**

IC202 BA6208

