

TA-F310R/F410R

SERVICE MANUAL

AEP Model
TA-F310R

Canadian Model
AEP Model
UK Model
E Model
TA-F410R



photo: TA-F410R

SPECIFICATIONS

Amplifier

Continuous RMS power output (both channels driven simultaneously)

AEP, West Germany models:

		TA-F310R	TA-F410R
DIN, 1 kHz	4 ohms	40 W + 40 W	70 W + 70 W
	8 ohms	29 W + 29 W	50 W + 50 W
20 Hz - 20 kHz THD 0.05%	4 ohms	27 W + 27 W	45 W + 45 W
	8 ohms	24 W + 24 W	35 W + 35 W

Canadian, UK and E models:

		TA-F410R
DIN, 1kHz	8 ohm only	70 W + 70 W
20 Hz - 20 kHz THD 0.05%		50 W + 50 W

Output

Output jack	Jack type	Voltage/impedance
REC OUT	Phono jacks	Voltage 150 mV Impedance 1 kohms
SPEAKERS	—	AEP, West Germany models Accepts speakers of 4 - 16 ohms. Canadian, UK and E models Accepts speakers of 8 - 16 ohms.
HEAD- PHONES	Stereo phone jack	Accepts low and high impedance headphones.

Tone controls

	Response	Turnover frequency
BASS	±8 dB (100 Hz)	500 Hz
TREBLE	±8 dB (15 kHz)	3 kHz

Input

Input jack	Jack type	Sensitivity	Impedance	S/N (weighting network, input level)
PHONO	MM	2.0 mV	50 kilohms	70 dB (A, 2 mV)
TUNER, CD, VIDEO/AUX, TAPE 1, TAPE 2/DAT	Phono	150 mV	50 kilohms	100 dB (150 mV)

Harmonic distortion

TA-F310R and TA-F410R UK, AEP and West Germany models:
Less than 0.7% at rated output

Other TA-F410R models:

Less than 0.05% at rated output

Intermodulation (IM) distortion (60 Hz:7 kHz = 4:1)

Less than 0.05% at rated output

Frequency response

PHONO: RIAA equalization curve

±0.5 dB

TUNER, CD, VIDEO/AUX, TAPE 1,

TAPE 2/DAT: 7 Hz - 100 kHz ±3 dB

Residual noise

Less than 170 μV (network A)

Damping factor

40 (8 ohms, 1 kHz)

—Continued on page 2—

INTEGRATED STEREO AMPLIFIER
SONY®

SECTION 4 DIAGRAMS

4-1. BLOCK DIAGRAM

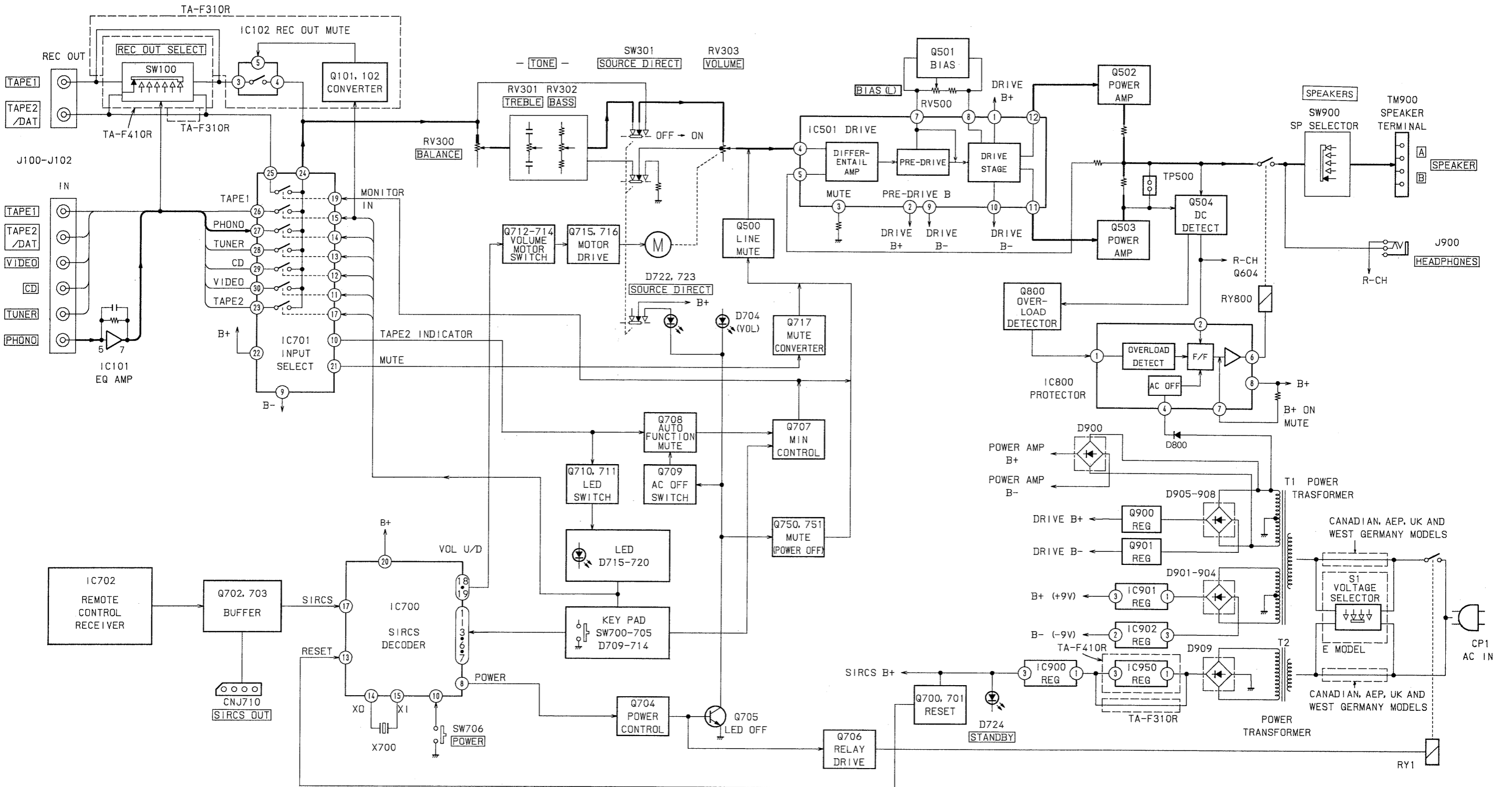

4-4. PRINTED WIRING BOARDS

- See page 8 for Circuit Boards Location and Semiconductor Lead Layouts.
- See page 9 for Semiconductor Location.

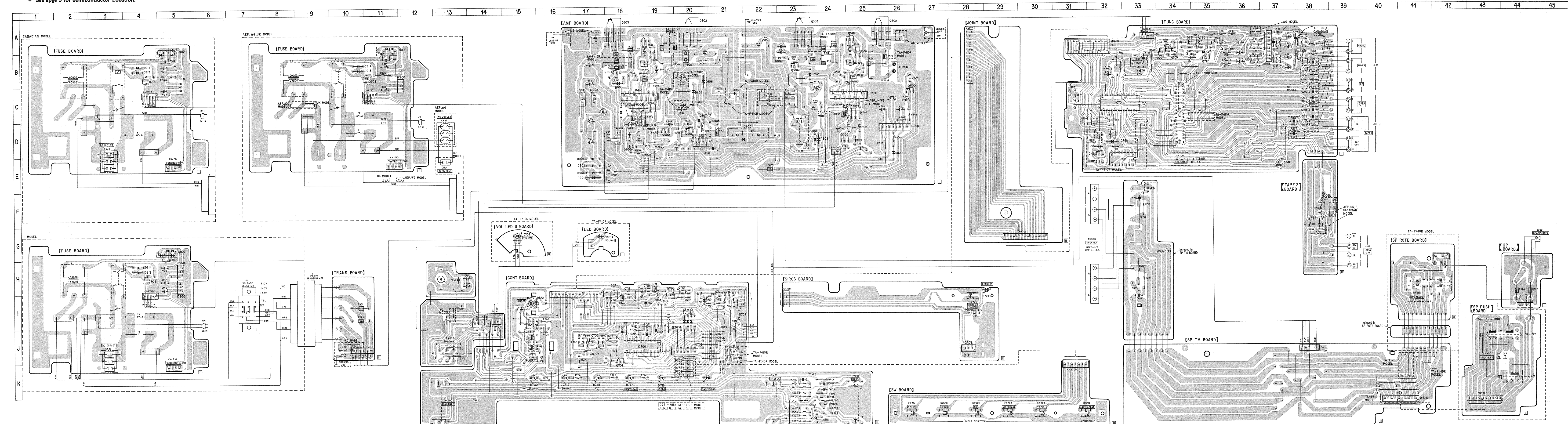

4-5. SCHEMATIC DIAGRAM

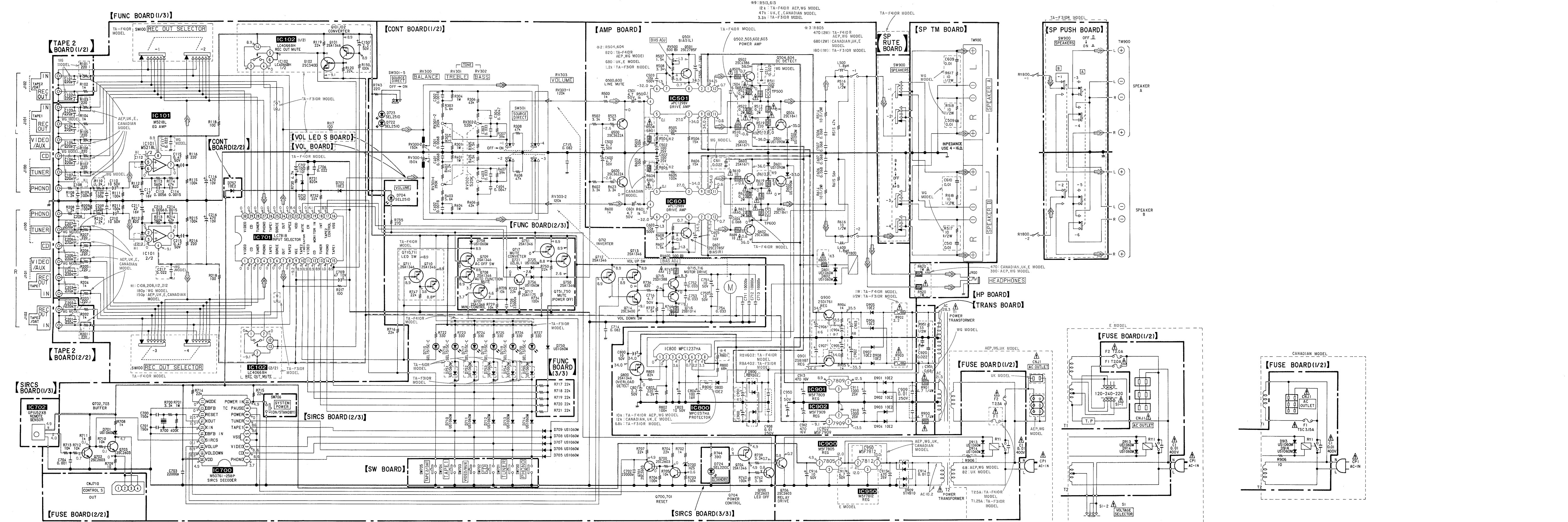

- All capacitors are in μF unless otherwise noted. pF: μF 50W or less are not indicated except for electrolytics and tantalums.
- All resistors are in Ω and $\frac{1}{4} W$ or less unless otherwise specified.
- \square : nonflammable resistor.
- \square : fusible resistor.
- \square : B + LINE
- \square : B - LINE
- \square : adjustment for repair.
- Voltage are dc with respect to ground under no signal conditions. no mark: PHONO
- Voltagcs are taken with a VOM. (input impedance 50K Ω)
- Voltage variations may be noted due to normal production tolerances.
- Signal path.
- \square : PHONO
- abbreviation
- WG: West Germany

Note: The components identified by mark Δ or dotted line with mark Δ are critical for safety. Replace only with part number specified.

Note: Les composants identifiés par une marque Δ ou une ligne pointillée avec une marque Δ sont critiques pour la sécurité. Ne les remplacer que par une pièce portant le numéro spécifié.

